

**HAWTHORN PARK LANDFILL  
APPENDIX III-4F  
HISTORICAL GROUNDWATER ANALYTICAL DATA**

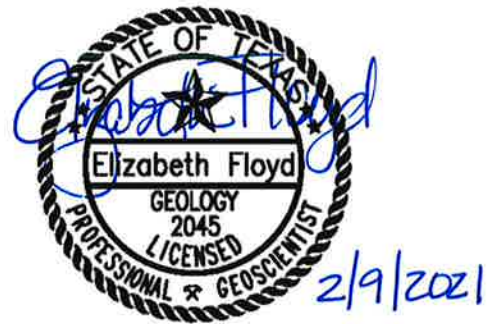

Biggs & Mathews Environmental, Inc.  
Firm Registration No. 50222



















Hawthorn Park Recycling & Disposal Facility  
Historical Groundwater Analytical Data  
Inorganics

Well ID	Sample Date	Alkalinity, Bicarbonate (as CaCO3) (mg/L)	Alkalinity, Carbonate (as CaCO3) (mg/L)	Alkalinity, Phenolphthalein (as CaCO3) (mg/L)	Alkalinity, Total (As CaCO3) (mg/L)	Arsenic (mg/L)	Barium (mg/L)	Cadmium, Dissolved (µg/L)	Cadmium, Total (µg/L)	Calcium (mg/L)	Chloride (mg/L)	Chromium (mg/L)	Copper (mg/L)	Dissolved Oxygen (Field) (mg/L)	Fluoride (mg/L)	Iron, Dissolved (µg/L)	Iron, Total (µg/L)	Lead (mg/L)	Magnesium (mg/L)	Manganese, Dissolved (µg/L)	Manganese, Total (µg/L)	Mercury (mg/L)	Nitrogen, Nitrate (mg/L)	pH (Field) (S.U.)	pH (Lab) (S.U.)	Potassium (mg/L)	Selenium (mg/L)	Silver (mg/L)	Sodium (mg/L)	Specific Conductance (Field) (UMHOS/CM)	Specific Conductance (Lab) (UMHOS/CM)	Sulfate (mg/L)	Total Dissolved Solids (TDS) (mg/L)	Total Organic Carbon - 1 (TOC) (mg/L)	Total Organic Carbon - 2 (TOC) (mg/L)	Total Organic Carbon - 3 (TOC) (mg/L)	Total Organic Carbon - 4 (TOC) (mg/L)	Zinc, Dissolved (µg/L)	Zinc, Total (µg/L)
	12/10/2004							<5		93				2.9		<60			1800				6.2	6.7					1080	1300	770	8.6	8.6	8.4	8.6	<20			
	12/19/2005							<5		59				2.8		<60			2400				6.59	6.7					1098	1400	850	6.9	6.9	7	7.1	<20			
	12/14/2006							<5		86				2.1		<60			2900				6.39	6.7					1374	1300	830	6.4	6.5	6.3	6.3	<20			
	12/18/2007							<5		62				2		70			2900				7.09	6.7					1194	1300	850	7.3	7	7.3	7	<20			
	12/29/2008							<5		79				3.3		<60			3000				6.3	6.6					1203	1300	830	6.2	6.1	6.2	6.1	<20			
	12/21/2009							<5		49				3		76			5500				6.1	6.7					1278	1900	1200	18	18	18	18	<20			
	12/9/2010							<5		61				2.9		<60			4200				6.59	6.58					1339	1900	1200	16	15	15	15	<20			
	12/1/2011							<2		55				0.8		83			4200				6.47	6.5					1761	2000	1200	17	17	17	17	<100			
	12/11/2012							<2		53				2		61			1800				6.6	6.71					1140	1400	870	9	8.7	8.7	8.8	<100			
	12/9/2013							<2		48				1		220			2100				6.49	6.64					1116	1100	720	13	13	13	13	<100			
	12/9/2014							2.2		59				1		300			2100				6.51	6.82					1111	770	690	3	2.9	2.9	2.8	<100			
	12/7/2015							<2		49				1.6		570			2600				6.55	7.02					1116	750	720	4.4	4.4	4.5	4.5	<100			
	12/19/2016							<2		98				1		570			2400				6.11	6.9					1414	1000	720	4.9	4.9	4.9	4.9	<100			
	12/11/2017							<2		100				1.2		640			2400				7.31	7.1					1449	1200	730	4.9	4.8	4.7	4.7	<100			
	12/17/2018							<2		110				1		580			2400				6.53	7.4					1188	1100	720	4	3.9	3.8	3.9	<100			
	12/12/2019							<2		83				0.9		490			2400				7.4	7.4					1218	1300	720	3.4	3.6	3.5	3.5	<100			
MW-20	7/26/1996	380	<5	<5	380	<0.02	0.42	<1		113	95	<0.003	<0.001		0.21	97		<0.05	18.6	14		<0.0004	1	6.79	0.85	<0.02	<0.004	53.5		1040	49	628	<1	<1	<1	1	8.8		
	9/25/1996	383	5	5	383	<0.02	0.42	<1		135	86.8	<0.003	<0.001		0.18	<60		<0.05	22.2	7.2		<0.0004	0.94	6.88	0.74	<0.02	<0.004	64		1000	55.6	436	3	1.8	<1	1.7	9.4		
	12/5/1996	432	<5	<5	432	<0.02	0.35	<1		134	77.1	<0.003	<0.001		0.19	<60		<0.05	21.8	4		<0.0004	0.74	6.89	0.65	<0.01	<0.004	65.9		1030	75.9	713	1.6	1.7	1.9	1.9	19		
	12/18/1997									84.3						<60			2.5				7.51						912	552	1	<1	<1	1.1					
	12/29/1998									78.4						100			11				7.41						794	468	4.6	4.8	4.8	4.6					
	12/14/1999									1.6						85			59				6.95						801	470	<1	<1	<1	<1					
	5/24/2000							<5											<15																		<20		
	12/7/2000									53.9						<60			16				7.25						783	423	1	1	<1	<1					
	1/23/2002							<5		49.5						<60			<15				6.9	7					662	714	499	<1	<1	<1	<1	<20			
	12/19/2002							<5		61						<60			<15				6.95	6.9					739	890	590	<1	<1	<1	<1	<20			
	12/15/2003							<5		55						<60			<15				6	7					840	890	580	1.8	1.7	1.5	1.6	<20			
	12/10/2004							<5		37				-0.2		<60			<15				6.89	7					657	950	570	3	2.9	2.9	2.7	<20			
	12/20/2005							<5		54				-0.2		<60			<15				6.77	6.9					988	1100	710	2.1	2.1	2	2.1	<20			
	12/14/2006							<5		39				1.3		<60			<15				6.73	6.9					942	980	640	1.3	1.2	1.2	1.2	<20			
	12/18/2007							<5		33				1.5		<60			<15				6.89	6.9					810	1000	620	2.5	2.5	2.6	2.6	<20			
	12/29/2008							<5		60				3		<60			460				6.2	6.6					1393	1600	1000	9.2	9.2	9.3	9.2	<20			
	12/21/2009							<5		25				2.4		<60			73				6.2	7.1					1429	920	580	<1	<1	<1	<1	<20			
	12/9/2010								<5	25				1.9		<60			18				6.67	7.01					859	840	520	<1	<1	<1	<1	<20			
	12/1/2011							<2		24				1.3		<60			17				6.94	6.98					801	850	530	<1	<1	<1	<1	<100			
	12/11/2012							<2		36				1.7		<60			58				7.13	6.95					746	1100	680	3.5	3.4	3.5	3.5	<100			
	12/9/2013							<2		34				1.1		<60			140				6.56	6.71					1071	1100	690	24	23	23	23	<100			
	12/8/2014							<2		42				1.1		<60			230				6.34	6.74					1276	790	810	5.8	5.7	5.7	5.7	<100			
	12/7/2015							<2		40				1.8		<60			440				6.24	7.01					1352	740	710	4.1	4.1	4	4	<100			
	12/19/2016							<2		46				1.6		<60			770				5.8	6.9					1460	1100	750	6.3	6.4	6.4	6.3	<100			
	12/11/2017							<2		54				1.4		<60			970				7.1	7					1630	1400	840	9.7	9.8	9.6	9.6	<100			
	12/17/2018							<2		45				0.7		<60			1000				5.96	7.1					1395	1100	850	11	10	10	10	<100			
	12/12/2019							<2		35				0.9		62			1200		</																		

Hawthorn Park Recycling & Disposal Facility  
 Historical Groundwater Analytical Data  
 Inorganics

Well ID	Sample Date	Alkalinity, Bicarbonate (as CaCO3) (mg/L)	Alkalinity, Carbonate (as CaCO3) (mg/L)	Alkalinity, Phenolphthalein (as CaCO3) (mg/L)	Alkalinity, Total (As CaCO3) (mg/L)	Arsenic (mg/L)	Barium (mg/L)	Cadmium, Dissolved (µg/L)	Cadmium, Total (µg/L)	Calcium (mg/L)	Chloride (mg/L)	Chromium (mg/L)	Copper (mg/L)	Dissolved Oxygen (Field) (mg/L)	Fluoride (mg/L)	Iron, Dissolved (µg/L)	Iron, Total (µg/L)	Lead (mg/L)	Magnesium (mg/L)	Manganese, Dissolved (µg/L)	Manganese, Total (µg/L)	Mercury (mg/L)	Nitrogen, Nitrate (mg/L)	pH (Field) (S.U.)	pH (Lab) (S.U.)	Potassium (mg/L)	Selenium (mg/L)	Silver (mg/L)	Sodium (mg/L)	Specific Conductance (Field) (UMHOS/CM)	Specific Conductance (Lab) (UMHOS/CM)	Sulfate (mg/L)	Total Dissolved Solids (TDS) (mg/L)	Total Organic Carbon - 1 (TOC) (mg/L)	Total Organic Carbon - 2 (TOC) (mg/L)	Total Organic Carbon - 3 (TOC) (mg/L)	Total Organic Carbon - 4 (TOC) (mg/L)	Zinc, Dissolved (µg/L)	Zinc, Total (µg/L)	
	12/5/1996	373	<5	<5	373	<0.02	0.79	<1		87.8	39	<0.003	<0.001		0.27	74	<0.05	17.3	4.9		<0.0004	0.2	7.09	7.09	0.7	<0.01	<0.004	48.6		718	10.1	496	83.2	1	<1	<1	<1	16		
	12/18/1997									51.6						<60			13				7.46							936	612	1.1	1.9	1	1.4					
	12/29/1998									27.8						200			8.7				7.24							715	399	3.3	3.6	3.1	3					
	12/14/1999									31.7						86			5.4				6.99							716	409	<1	<1	<1	<1					
	5/24/2000							<5											<15																				<20	
	12/7/2000									28.8						<60			6.9					7.36						687	389	<1	<1	<1	<1					
	1/23/2002							<5		21.1					<60				<15				7.2	7.1				806	599	416	<1	<1	<1	<1	<1	<1	<20			
	12/19/2002							<5		27					<60				<15				6.91	7				589	640	400	<1	<1	<1	<1	<1	<1	<20			
	12/15/2003							<5		30					<60				<15				7.15	7.1				722	690	410	1	1	1	1	1	<1	<20			
	12/10/2004							<5		30				0.1	<60				<15				7	7.1				528	720	400	1.4	1.4	1.4	1.4	1.4	<1	<20			
	12/20/2005							<5		31				-0.1	<60				<15				7.11	7.2				542	700	410	<1	<1	<1	<1	<1	<1	<20			
	12/14/2006							<5		30				-0.3	<60				<15				7.1	7.1				714	700	410	<1	<1	<1	<1	<1	<1	<20			
	12/18/2007							<5		26				0.4	<60				<15				7.21	7.1				692	740	440	<1	<1	<1	<1	<1	<1	<20			
	12/29/2008							<5		27				3.1	<60				<15				6.6	6.9				693	780	460	<1	<1	<1	<1	<1	<1	<20			
	12/21/2009							<5		28				3.9	<60				<15				6.9	7.1				695	720	400	<1	<1	<1	<1	<1	<1	<20			
	12/9/2010								<5	26				2.8		<60			<15				6.28	7.22				785	720	400	<1	<1	<1	<1	<1	<1	<20			
	12/1/2011								<2	22				1.4		<60			<15				7.04	7.05				729	750	450	<1	<1	<1	<1	<1	<1	<100			
	12/11/2012								<2	24				2.6		130			49				6.74	7.12				1071	830	480	<1	<1	<1	<1	<1	<1	<100			
	12/9/2013								<2	28				1.7		69			<15				6.95	6.99				773	780	460	18	19	19	18	18	<1	<100			
	12/8/2014								<2	25				1.3		<60			<15				6.73	6.1				819	570	480	<1	<1	<1	<1	<1	<1	<100			
	12/7/2015								<2	26				1.7		<60			<15				6.99	7.45				891	520	460	<1	<1	<1	<1	<1	<1	<100			
	12/19/2016								<2	22				1.9		<60			<15				6.42	7.3				947	720	470	<1	<1	<1	<1	<1	<1	<100			
	12/11/2017								<2	77				2.1		220			390				6.18	7				1258	1400	920	33	32	33	33	33	<100				
	12/17/2018								<2	110				1.4		790			710				5.84	6.8				1990	1800	1300	67	68	70	67	67	<100				
	12/12/2019								<2	150				0.9		2100			1000				6.9	7				2310	2400	1600	100	99	100	100	100	<100				

Hawthorn Park Recycling & Disposal Facility  
Historical Groundwater Analytical  
Organics

Well ID	Sample Date	1,1,1,2-Tetrachloroethane (µg/L)	1,1,1-Trichloroethane (µg/L)	1,1,2,2-Tetrachloroethane (µg/L)	1,1,2-Trichloroethane (µg/L)	1,1-Dichloroethane (µg/L)	1,1-Dichloroethene (µg/L)	1,2,3-Trichloropropane (µg/L)	1,2-Dibromo-3-chloropropane (µg/L)	1,2-Dibromoethane (EDB) (µg/L)	1,2-Dichlorobenzene (µg/L)	1,2-Dichloroethane (µg/L)	1,2-Dichloropropane (µg/L)	1,4-Dichlorobenzene (µg/L)	2-Butanone (MEK) (µg/L)	2-Hexanone (µg/L)	4-Methyl-2-pentanone (µg/L)	Acetone (µg/L)	Acrylonitrile (µg/L)	Benzene (µg/L)	Bromochloromethane (µg/L)	Bromodichloromethane (µg/L)	Bromoform (µg/L)	Bromomethane (µg/L)	Carbon Disulfide (µg/L)	Carbon Tetrachloride (µg/L)	Chlorobenzene (µg/L)	Chloroethane (µg/L)	Chloroform (µg/L)	Chloromethane (µg/L)	Cis-1,2-Dichloroethene (µg/L)	Cis-1,3-Dichloropropene (µg/L)	Dibromochloromethane (µg/L)	Dibromomethane (µg/L)	Ethylbenzene (µg/L)	Iodomethane (µg/L)	Methylene Chloride (µg/L)	Tetrachloroethene (µg/L)	Toluene (µg/L)	trans-1,2-Dichloroethene (µg/L)	trans-1,3-Dichloropropene (µg/L)	trans-1,4-Dichloro-2-butene (µg/L)	Trichloroethene (µg/L)	Trichlorofluoromethane (µg/L)	Vinyl acetate (µg/L)	Vinyl Chloride (µg/L)	Xylenes (total) (µg/L)	
MW-14	5/24/2000	<5	<5	<5	<5	<5	<5	<5	<5	<10	<5	<5	<10	<100	<50	<50	<100	<5	<5	<5	<5	<5	<10	<5	<5	<10	<5	<10	<5	<5	<5	<10	<5	<5	<5	<5	<5	<5	<5	<5	<5	<5	<5	<5	<5	<5		
	2/1/2002	<5	<5	<5	<5	<5	<5	<10	<1	<1	<10	<5	<5	<10	<10	<10	<34	<100	<5	<5	<5	<5	<10	<5	<5	<5	<5	<5	<10	<5	<5	<10	<5	<5	<5	<5	<5	<5	<5	<5	<5	<5	<5	<5	<5	<5	<5	<5
MW-18	5/24/2000	<5	<5	<5	<5	<5	<5	<5	<5	<10	<5	<5	<10	<100	<50	<50	<100	<5	<5	<5	<5	<5	<10	<5	<5	<5	<10	<5	<10	<5	<5	<5	<5	<10	<5	<5	<5	<5	<5	<5	<5	<5	<5	<5	<5	<5	<5	<5
MW-19	5/24/2000	<5	<5	<5	<5	<5	<5	<5	<5	<10	<5	<5	<10	<100	<50	<50	<100	<5	<5	<5	<5	<5	<10	<5	<5	<5	<10	<5	<10	<5	<5	<5	<5	<10	<5	<5	<5	<5	<5	<5	<5	<5	<5	<5	<5	<5	<5	<5

**HAWTHORN PARK LANDFILL  
APPENDIX III-4G  
MCBRIDE-RATCLIFF ASSOCIATES, INC. – GEOLOGIC FAULT  
ASSESSMENT**

APPENDIX D  
GEOLOGIC FAULT ASSESSMENT  
HAWTHORN PARK RECLAMATION PROJECT  
AND RECYCLING CENTER  
HARRIS COUNTY, TEXAS

Prepared For

SANIFILL OF TEXAS, INC.  
HOUSTON, TEXAS

Prepared By

McBRIDE-RATCLIFF AND ASSOCIATES, INC.  
HOUSTON, TEXAS  
JANUARY 1993

## TABLE OF CONTENTS

	<u>Page No.</u>
<b>INTRODUCTION</b> .....	D-1
<b>PHASE ONE - SURFACE FAULT EVALUATION</b> .....	D-2
Scope of Work .....	D-2
Fault Characteristics .....	D-2
Fault Activity .....	D-3
Geologic Literature and File Search .....	D-3
Topographic Map Analysis .....	D-6
Remote-Sensing Analysis .....	D-7
Site and General Area Reconnaissance .....	D-8
<b>PHASE TWO FAULT EVALUATION</b> .....	D-9
<b>SUBSURFACE INVESTIGATION</b> .....	D-9
<b>ANALYSIS OF SUBSURFACE DATA</b> .....	D-10
<b>CONCLUSIONS</b> .....	D-12

## LIST OF ILLUSTRATIONS

Figure No.	Title
D-1	Van Sieten 1966 Fault Map
D-2	Heuer 1979 Fault Map
D-3	Van Sieten Trammel Crow Tract 1980 Fault Study Map
D-4	Benchmark Map
D-5	Site Vicinity Map
D-6	Map Showing HPRPRC Site Relationship To The Brittmoore Fault and the White Oak Fault
D-7	Testhole Locations
D-8	Cross-section A-A'
D-9	Cross-section B-B'
D-10	Cross-section C-C'
D-11	Cross-section D-D'
D-12	Cross-section D-D' (continued)
D-13	Cross-section E-E'
D-14	Cross-section F-F' & G-G'
D-15	Cross-section H-H'



## APPENDIX D

### 330.65 (b)(5)(J) GEOLOGIC FAULT ASSESSMENT

#### Introduction

The requirements of the Texas Water Commission (TWC) Municipal Solid Waste Management Regulations (MSWMR) section 330.65 (b)(5)(J) Active Geologic Faults states, "a site located in areas subject to differential subsidence or active geological faulting must include detailed fault studies" in the permit application. The Hawthorn Park Reclamation Project and Recycling Center (HPRPRC) is located in Harris County, Texas. Parts of Harris County are effected by active geologic faults and subsidence. Presented in the following sections is our fault evaluation for the HPRPRC site.

Various investigative techniques have been outlined in the above referenced regulations. These techniques consist of the following:

- (i) Structural damage to constructed facilities (roadways, railways, and buildings).
- (ii) Scarps in natural ground.
- (iii) Presence of surface depressions (sag ponds and ponded water).
- (iv) Lineations noted on aerial maps and topographic sheets.
- (v) Structural control of natural streams.
- (vi) Vegetation changes.
- (vii) Crude oil and natural gas accumulations.
- (viii) Electrical spontaneous potential and resistivity logs (correlation of subsurface strata to check or stratigraphic offsets).
- (ix) Earth electrical resistivity surveys (indications of anomalies which may represent fault planes).
- (x) Open trench excavations (visual examinations to detect changes in subsoil texture and/or weathering indicating stratigraphic offsets).
- (xi) Changes in elevations of established benchmarks.
- (xii) References to published geological literature pertaining to area conditions.

Our fault evaluation is presented in two phases. Phase one presents our report of surface fault evidence, addresses clauses (i), (ii), (iii), (iv), (v), (vi), (vii), (x), (xi), and (xii) of MSWMR 330.65 (b)(5)(J). Phase Two of our report presents our subsurface evaluation for the presence of possible on-site faults, and addresses clauses (viii) and (ix) of MSWMR 330.65(b)(5)(J). Each clause is noted in our report.

The results of our study are that the HPRPRC site is not traversed by an active fault. The zones of influence of active faults in the vicinity have been identified and these zones of influence will not impact the containment design of the landfill. Our study also shows the HPRPRC site is not effected by localized differential subsidence.

#### Phase One - Surface Fault Evaluation

Presented in this section are the results of our Phase One Surface Fault Evaluation. The purpose of this section is to identify surface evidence which may indicate the presence of a fault being located on-site or near a site.

Scope of Work. Our Phase 1 assessment of the potential for surface faulting at the HPRPRC site included the following tasks:

- Review of geologic literature and our file data pertaining to surface fault documentation within the general vicinity of the site
- Analysis of topographic maps for geomorphic features which may represent surface fault activity
- Remote-sensing analysis utilizing black and white and false-colored infrared aerial photography to check for photo linears which may be related to surface faults
- Site and general area reconnaissance to check for physical evidence of distress resulting from surface fault activity.

These tasks were conducted in general accordance with the March 1985 Houston Geological Society Bulletin *Recommended Standards of Practice for Investigating Geologic Faults in the Texas Gulf Coast Region.*

Fault Characteristics. The entire gulf coast of Texas is underlain by a thick wedge of sediments. Exploration, principally by the petroleum industry, has identified these sediments to be extensively disrupted by "growth" faults and faults associated with shallow piercement and deep-seated salt domes.

The Texas Gulf Coastal Plain is traversed by numerous growth faults. Growth faults are essentially slip surfaces formed by "landslides" that occurred at the same time of sediment deposition. The subsurface displacement of strata increases with depth. Faults associated with salt domes are similar to growth faults in that the faulting takes place in the sediments, but the mode of deformation is generated by mobile salt migration.

The inclination of the fault planes is a few degrees from vertical. The width of the fault zones has not been researched extensively. Our observations of distress in structures over active faults in other parts of Houston suggest that the vertical displacement may occur on more than one plane, and in a zone several feet wide. Secondary motions consisting of buckling or folding of beds adjacent to the fault are noted paralleling the fault trace.

**Fault Activity.** Evidence of continuing activity of faults is demonstrated by minor topographic scarps and aligned ponded water on virgin land, and disruption of pavements, structures, land subsidence, etc., in developed areas. The relationship of mapped subsurface faults and ground-surface displacement related to faults has been demonstrated by various researchers.

Most investigators relate current rates of ground surface displacement in the Houston-Galveston area by faulting to the removal of groundwater, and to a lesser extent, oil and gas in the relatively shallow subsurface. Extensive groundwater development began in the late thirties and has increased to the present. These investigators believe the near-surface movement of faults in the area is due to differential consolidation of sediments bounding the faults. Sediments are depressured by heavy pumping, thus inducing consolidation. It is postulated that this differential consolidation is manifested in movement along the pre-existing fault planes, which is then propagated to the surface.

The HPRPRC site fault evaluation was conducted using four lines of evidence: geologic literature and MRA file data, topographic maps, aerial photographs, and site reconnaissance. Each line of evidence was assessed individually then in conjunction with observations from other evidence.

**Geologic Literature and File Search.** The work presented in this sections covers MSWMR 330.65(b)(5)(J) clauses (xii) References to published geological literature pertaining to area conditions, (vii) Crude oil and natural gas accumulations, and (xi) Changes in elevations of established benchmarks.

Past area studies performed by our geologic staff have indicated that the site is located in an area traversed by a regional fault system designated as the Addicks Fault System. Based on area experience, the Addicks fault system is composed of five en-echelon segments (parallel sections of off-set fault lines). Each segment is characterized as a down the coast oriented fault. The faults are situated on a trend of about southwest to northeast traversing about 28 miles of west and north Harris County, Texas. Associated with the down the coast faults are two antithetic faults (faults formed due to stresses related to the movement of the down the coast faults). The antithetic faults are up the coast oriented faults. The Addicks Fault System includes the down the coast Addicks, Brittmoore, Breen,

Woodgate, and Hardy faults. The up the coast antithetic faults include the White Oak and the West faults. The HPRPRC site is situated southeast of the Brittmoore Fault and southwest of the White Oak Fault.

In a report published by Turner Collie and Braden, Inc. of Houston in 1966, Dewitt C. Van Sicien presented a map which represented his interpretation of the surface location of faults in the general vicinity of the study area. Figure D-1 illustrates the Van Sicien fault map. Van Sicien has interpreted the surface location of 2 faults in the area of the HPRPRC site. Fault 1 represents Van Sicien's interpretation of the surface location of the Brittmoore Fault. Fault 2 is Van Sicien's representation of the surface location of an interpreted "possible" fault (projection of the White Oak Fault). As illustrated on Figure D-1 Fault 2 traverses the middle of the HPRPRC site.

As a partial fulfillment of the Master Degree in geology at the University of Houston, Wolfgang C. Heuer presented his 1979 thesis entitled *Active Faults In The Northwestern Houston Area*. The HPRPRC site is situated in Heuer's mapping area. Figure D-2 illustrates the interpreted location of faults and "possible" fault related features interpreted by Heuer in the area of the HPRPRC site. As shown on Figure D-2, the fault features designated as 10, 10A, and 10B are located in the HPRPRC site.

A 1980 report by Dewitt Van Sicien to Trammell Crow Company entitled *Geologic Fault Investigation West by Northwest Business Park Fairbanks Area Harris County, Texas*, presents a surface and subsurface fault evaluation for a site located northwest of the HPRPRC site. This study site is situated on line with the projection of the White Oak Fault and the HPRPRC site. Figure D-3 illustrates the location of the Van Sicien study site with respect to the HPRPRC site and the White Oak Fault. The conclusions of the report in part state:

No faulting is present on the West by Northwest Business Park property within the 400-ft depth of investigation. The age of the strata at this depth is not known, but a reasonable estimate would be early Pleistocene, more than 1,000,000 years old.

The second phase of the geologic literature search concentrated on addressing MSWMR 330.65(b)(5)(J) clause (vii) **Crude oil and natural gas accumulations.**

Petroleum accumulations in the Gulf Coast of Texas have been identified as being controlled by deep subsurface faults, salt domes and salt-dome-formed anticlinal bedding, and radial faults associated with salt dome structures. Sources of evidence used to evaluate the area for crude oil and natural gas accumulations included the revised 1982 *Geologic Atlas of Texas, Houston Sheet*, the 1983 Bureau of Economic Geology *Atlas of Major Texas Oil*

*Reservoirs*, and the 1991 Geomap Company Upper Texas Gulf Coast Map Number - UTGC 4, dated April 26, 1991.

As shown in the literature the HPRPRC disposal area site is located about 1 mile southwest of the southwest flank of the Fairbanks oil and gas field. Petroleum accumulations for the Fairbanks field are reported as associated with faulted and anticlinal structure associated with the formation of a deep seated salt dome and regional faulting.

Based on our knowledge of the location of the Brittmooore Fault, it is our interpretation that this fault traverses much of the Fairbanks oil and gas field.

Well sites located in the HPRPRC site area are reported on the Geomap Company map as being dry holes. Petroleum accumulations thought to exist at the well sites have either been depleted by production or are non-existing in the area explored by the wells.

The third phase of our geologic literature search address MSWMR 330.65(b)(5)(J) clause (xi) **Changes in elevations of established benchmarks.**

A review of benchmark levelling data for a total of 15 benchmarks, located as shown on Figure D-5, was performed for this task. These benchmarks represent the National Geodetic Survey (NGS) benchmarks in a 3 mile radius of the site. The data was provided by the Harris-Galveston Coastal Subsidence District. The table below presents a summary of the data reviewed.

SUMMARY OF BENCHMARK DATA					
Benchmark No.	1973 Elev. Ft, MSL	1978 Elev. Ft, MSL	Difference (1978-1973) Ft	1987 Elev. Ft, MSL	Difference (1987-1978) Ft
1		92.176		90.253	-1.923
2	96.013	95.322	-0.691	93.515	-1.807
3	101.226	100.459	-0.767	98.551	-1.908
4				96.524	
5	107.276	106.572	-0.704	104.421	-2.151
6		108.552		106.513	-2.039
7		110.303		108.318	-1.985

SUMMARY OF BENCHMARK DATA					
Benchmark No.	1973 Elev. Ft, MSL	1978 Elev. Ft, MSL	Difference (1978-1973) Ft	1987 Elev. Ft, MSL	Difference (1987-1978) Ft
8	90.685	89.768	-0.917	87.757	-2.011
9				89.926	
10	94.090	93.375	-0.715	91.694	-1.681
11	94.907	94.218	-0.689	92.489	-1.729
12	93.209	92.969	-0.240	90.945	-2.024
13				114.553	
14	111.797	111.200	-0.597	109.245	-1.955
15	115.757	115.290	-0.467	113.063	-2.227

The above data shows, for the time period between 1973 and 1978 that an average subsidence rate of 0.129 ft/yr was exhibited for the area encompassed by the benchmarks. Between the time period 1978 and 1987, the average subsidence rate is 0.217 ft/yr or an increase of 0.088 ft/yr (about 1 inch).

The observed subsidence appears on a regional scale and not exhibiting large variations in measurements between benchmarks. It is our opinion that the area encompassed by the benchmarks is exhibiting subsidence that is regional to the site vicinity.

**Topographic Map Analysis.** The topographic map analysis allows for the identification of surface features which may have been manifested by a fault. These features include scarps, aligned natural drainage features, and/or aligned ponded waters. This section addresses the following MSWMR 325.74 (b)(5)(J) clauses:

1. (ii) Scarps in natural ground
2. (iii) Presence of surface depressions
3. (iv) Lineations noted on aerial maps and topographic sheets
4. (v) Structural control of natural streams

Historic topographic maps of Harris County, Texas were completed in the early 1900's using a 1-ft contour interval. These maps are very useful in identifying topographic features which may be manifested by faults in the relatively flat Harris County area of which the HPRPRC disposal area is located.

The site is located on the 1918 Hillendahl, Texas topographic map (Figure D-4). No evidence of on-site topographic scarps related to active faulting was identified. The surface topography as shown on the 1918 Hillendahl topographic map is marked by an extensive area of "pocky" topography. This type of topography is indicative of distributary channel fill depositional environments and wind blown surface features of the silty top soil covering most of the Lissie Formation identified throughout Harris County, Texas. This topographic feature is not interpreted as being manifested by a fault. No evidence of lineations or topographic scarps were observed during our review of the 1918 Hillendahl topographic map at the site. A drainage system located north of the site is shown on the topographic map as changing trend from southwest - northeast to northwest - southeast. It is our interpretation that this drainage system formed as a result of headward erosion and is controlled by a distributary channel fill depositional environments traversing the area.

**Remote-Sensing Analysis.** The use of aerial photographs is a useful tool in the recognition of surface evidence which may be manifested by a fault. The performance of our remote-sensing analysis addresses the following MSWMR 325.74(b)(5)(J) clauses:

1. (iii) Presence of surface depressions
2. (iv) Lineations noted on aerial maps and topographic sheets
3. (v) Structural control of natural streams
4. (vi) Vegetation changes

The aerial photographs which were used for the remote-sensing analysis included black and white photographs from the years 1953, 1957, 1964, and 1987. A 1981 NASA high altitude false colored infra-red photo imagery was also reviewed during our remote-sensing analysis.

Aligned surface depressions may form along the downthrown side of a fault. Also a lineation or "photo-linear" may be identified on photo imagery in areas where a fault scarp has experienced the accumulation of water on the downthrown side of a fault. No on-site photo linears or aligned surface depressions were interpreted as being located in the HPRPRC site. A faint to distinct photo-linear was identified off-site in the area coincident to the surface location of the Brittmoore Fault.



As stated above in the topographic map analysis a drainage featured is situated north of the site. This feature changes trend near the surface location of the Brittmoore Fault.

No discrete vegetative changes which we interpret as being the product of on-site faults were identified during our remote-sensing analysis. Subtle color change noticed along the photo-linear of the Brittmoore Fault are interpreted as locating minor vegetative changes due to the change in moisture content from the upthrown side of the fault to the downthrown side.

Site and General Area Reconnaissance. A site and general area reconnaissance is performed for the purpose of identifying specific evidence that may be interpreted as being the product of an active fault. The reconnaissance was performed by driving through the area encompassing the site, walking and viewing subtle surface features, viewing area drainage features, excavations, and open fields for evidence of a fault. This section of our report addresses the following MSWMR 325.74(b)(5)(J) clauses:

1. (i) Structural damage to constructed facilities
2. (ii) Scarps in natural ground
3. (vi) Vegetation changes
4. (x) Open trench excavations

Site reconnaissance for the HPRPRC site has been performed on a number of occasions from 1986 with the most recent being January 16, 1992. Except where noted, the following discussion references the reconnaissance of January 16, 1992.

Our on-site reconnaissance did not reveal the presence of structural damage which we interpret as being manifested by an active fault to site specific roads or building structures. No topographic scarps or vegetation changes were identified in the site boundaries. Exposed side walls of excavation for the existing facility did not reveal the presence of a fault or stratigraphic displacement of bedding planes.

Areas of off-site concern which were reviewed during our reconnaissance included the location of the Brittmoore Fault and the White Oak Fault. Figure D-6 illustrates the relationship of the location of the Brittmoore Fault and the White Oak Fault to the HPRPRC site. The surface location of these faults were mapped on January 16, 1992. As shown, the HPRPRC site is not traversed by either fault. Surface evidence of the White Oak faults terminates northwest of the site about 2 miles. Surface evidence of the White Oak Fault was noted on a northeast trend away



from the HPRPRC site. A well defined scarp identifies the surface location of the Brittmoore Fault throughout the vicinity. Structural distress in roads and building structures situated above both faults indicate that these faults are active.

During our site reconnaissance, observations were made relative to the horizontal distress visible in areas where the Brittmoore Fault crossed beneath rigid structures. The zone of influence for the fault is defined as an area parallel to the fault line which exhibits distress related to the movement of the fault. Our measurements were obtained on a line perpendicular to the fault line for both the upthrown and downthrown sides of the fault. The measurements were obtained along Empire Central Drive, Dac Road, Brittmoore Road at Holly Hill, McGinty Road, and Cunningham Road. The areas where measurements were obtained are located near the site, are crossed by the fault, and demonstrate structural distress. A summary of the measurements are presented in the following table.

<b>SUMMARY OF ZONE OF INFLUENCE OBSERVATIONS BRITTMOORE FAULT</b>			
Location of Measurement	Observations, FT		Total Zone of Influence
	Upthrown Side	Downthrown Side	
Empire Central Drive	30	100	130
Dac Road	25	100	125
Brittmoore @ Holly Hill	30	120	150
McGinty Road	20	85	105
Cunningham Road	35	100	135

Based on the data presented and our experience with fault movements in the Houston area it is our interpretation that a representative zone of influence for the Brittmoore Fault could be as much as 200 ft on the downthrown side and 75 ft on the upthrown side or a total of 275 ft. The project site is located outside of this zone.

#### Phase Two Fault Evaluation

Our Phase Two study addresses MSWMR 325.74(b)(5)(J) regulation, "when an active fault is known to exist within one-half mile, the site shall be investigated for unknown faults". This portion of our report addresses the following clauses:

1. (viii) Electrical spontaneous potential and resistivity logs (correlation of subsurface strata to check for stratigraphic offsets), and
2. (ix) Earth electrical resistivity surveys.

### Subsurface Investigation

The use of earth resistivity surveys is a useful tool for evaluating the subsurface for faults given that the conditions are conducive for use of this method. Surface resistivity curves are dominantly measuring the electrolytic properties of subsoil fluids. This method was not used for this investigation due to the fact that dewatering of the subsurface strata has been employed at the site. Dewatering was required for the past sand mining operations of the site and adjacent areas. Thus, our subsurface investigation used geophysical logging techniques employing spontaneous potential, single point resistance, and natural gamma ray curves for subsurface strata identification in deep test holes.

Thirty-two test holes located as shown on Figure D-7, were drilled, geophysically logged, and grouted for the subsurface evaluation of the HPRPRC site. A testhole depth of 300 ft below the ground surface was selected to penetrate stratigraphic units which could be readily correlated over the site. Geophysical logs were obtained immediately upon completion of the drilling. Three geophysical curves were obtained from each log, natural gamma ray, spontaneous potential, and single-point resistance. The three curves are interpreted to identify distinct stratigraphic units, referred on the cross-sections as Marker Beds. The logs are placed in a cross-sectional form and are analyzed to identify subsurface anomalies which are characteristic of faults.

The subsurface test holes were drilled on different time periods. All test holes were drilled by personnel of Buford Drilling Company, Inc. of Houston, Texas. The geophysical logs for B-1 through B-19 were obtained by Mr. Chuck Daniels, deceased, of CEDCo Logging Company. The geophysical logs for B-20 through B-32 were obtained by personnel of MRA using a CoLog Inc. geophysical logging unit.

### Analysis of Subsurface Data

The subsurface stratigraphy is represented by geophysical log cross-sections as shown on Figures D-8 through Figure D-15. The stratigraphic markers represent our interpretation of some of the common markers located throughout the subsurface. The following table summarizes our interpretation of Marker locations.

## SUMMARY OF MARKER BED DEPTHS AND ELEVATIONS

Test Hole Number	Surface Elevation	Marker A		Marker B		Marker C	
		Depth (ft)	Elev. (ft) msl	Depth (ft)	Elev (ft) msl	Depth (ft)	Elev (ft) msl
B-1	106	264	-158	160	-54	52	+54
B-2	105	264	-159	164	-59	52	+53
B-3	104	262	-158	164	-60	55	+49
B-4	103	262	-159	164	-61	58	+45
B-5	103	261	-158	166	-63	54	+48
B-6	103	261	-158	168	-65	58	+45
B-7	104	262	-158	162	-58	56	+48
B-8	103	262	-159	160	-57	52	+51
B-9	103	262	-159	160	-57	56	+47
B-10	106	264	-158	160	-54	54	+52
B-11	104	260	-156	166	-62	56	+48
B-12	103	261	-158	164	-61	56	+47
B-13	103	262	-159	162	-59	56	+47
B-14	106	264	-158	164	-58	60	+46
B-15	103	261	-158	162	-59	56	+47
B-16	105	262	-157	166	-61	54	+51
B-17	105	261	-156	166	-61	58	+47
B-18	103	263	-160	160	-57	52	+51
B-19	105	260	-155	162	-57	52	+53
B-20	103	260	-157	162	-59	58	+45
B-21	103	263	-160	162	-59	58	+45
B-22	102	262	-160	164	-62	60	+42
B-23	100	258	-158	164	-64	60	+40
B-24	100	258	-158	166	-66	56	+44
B-25	100	258	-158	166	-66	58	+42
B-26	99	259	-160	164	-65	54	+45
B-27	100	258	-158	158	-58	56	+44
B-28	101	256	-155	162	-61	54	+47
B-29	101	258	-157	161	-60	60	+41
B-30	101	258	-157	164	-63	58	+43
B-31	102	258	-156	164	-62	56	+46
B-32	104	260	-156	166	-62	58	+46

Marker A was identified between elevations -155 ft, MSL to about -160 ft, MSL. This marker is interpreted to represent a boundary between a channel fill sand layer and an overlying clay layer. As illustrated on the geophysical log cross-sections, Figure D-7 through Figure D-14, no offset of Marker A has been identified which we would interpret as the manifestation of a fault.

Marker B was identified at about elevation -54 ft at B-1 to -66 ft at B-24 and B-25. This marker represents the boundary between the base of channel fill sand layers and overlying clay layers. Based on our log cross-section review (Figure D-7 through D-14), it is our interpretation that no stratigraphic offset which we interpret as the manifestation of a fault has been identified.

Marker C as exhibited on the geophysical log cross-sections, Figures D-7 through Figure D-14, represents the boundary between distributary channel fill sand layers and underlying clay layers. This marker was identified at about elevation +41 ft at B-29 to about +54 ft at B-1. Based on our review of the geophysical log cross-sections, it is our interpretation that no stratigraphic offsets indicative of faulting have been identified.

Our interpretation of the geophysical data did not reveal evidence indicative of geologic faulting.

### Conclusions

Several lines of evidence have been analyzed to identify features which represent the manifestation of surface faulting with respect of the proposed HPRPRC disposal area site located in Harris County, Texas. Our study was conducted in general accordance with MSWMR 325.74(b)(5)(J). **Active Geologic Faults.** Our conclusions follow:

1. Based on our review of all evidence identified we do not interpret the site as being traversed or along the projected trend of an active surface fault.
2. A review of geologic literature showed that the site is located about 1850 ft southeast of the Brittonmoore Fault.
3. Several documented features termed "possible faults" were mapped by Dewitt VanSiclen and Wolfgang Heuer as being located in the site boundaries.
4. An analysis of topographic maps and aerial photographs did not identify features we interpret as the manifestation of surface faulting within the boundaries of the site.

5. The site area is experiencing regional subsidence. Our review of benchmark data through 1987 show the subsidence between 1978 and 1987 to be between (-1.681 ft) and (-2.227 ft).
6. A site reconnaissance of the area adjacent to the site did identify structural damage to roadways and building structures situated above the Brittmooore Fault. The trend of the Brittmooore Fault was mapped and does not traverse or project to the HPRPRC site.
7. The White Oak Fault is active along a southwest to northeast trend about 2 miles northeast of the HPRPRC site. Evidence produced by Dewitt Van Siclen (for a site situated between the HPRPRC site and the last known point of surface evidence of the White Oak Fault) indicates that the fault either terminates northeast of the site or dips beneath the surface at a depth greater than 400 ft beneath the groundsurface.
8. The zone of influence for the Brittmooore Fault as measured at two locations traversed by the fault shows a zone of influence of about 100 ft. The greatest observed distress was on the downthrown side of the fault. The HPRPRC site is located outside of the interpreted zone of influence for fault movement associated with the Brittmooore Fault.
9. A subsurface geophysical logging project was performed to evaluate the potential of the HPRPRC site as being traversed by a fault. Our interpretation of the geophysical log cross-sections developed for the site did not reveal the presence of a fault.



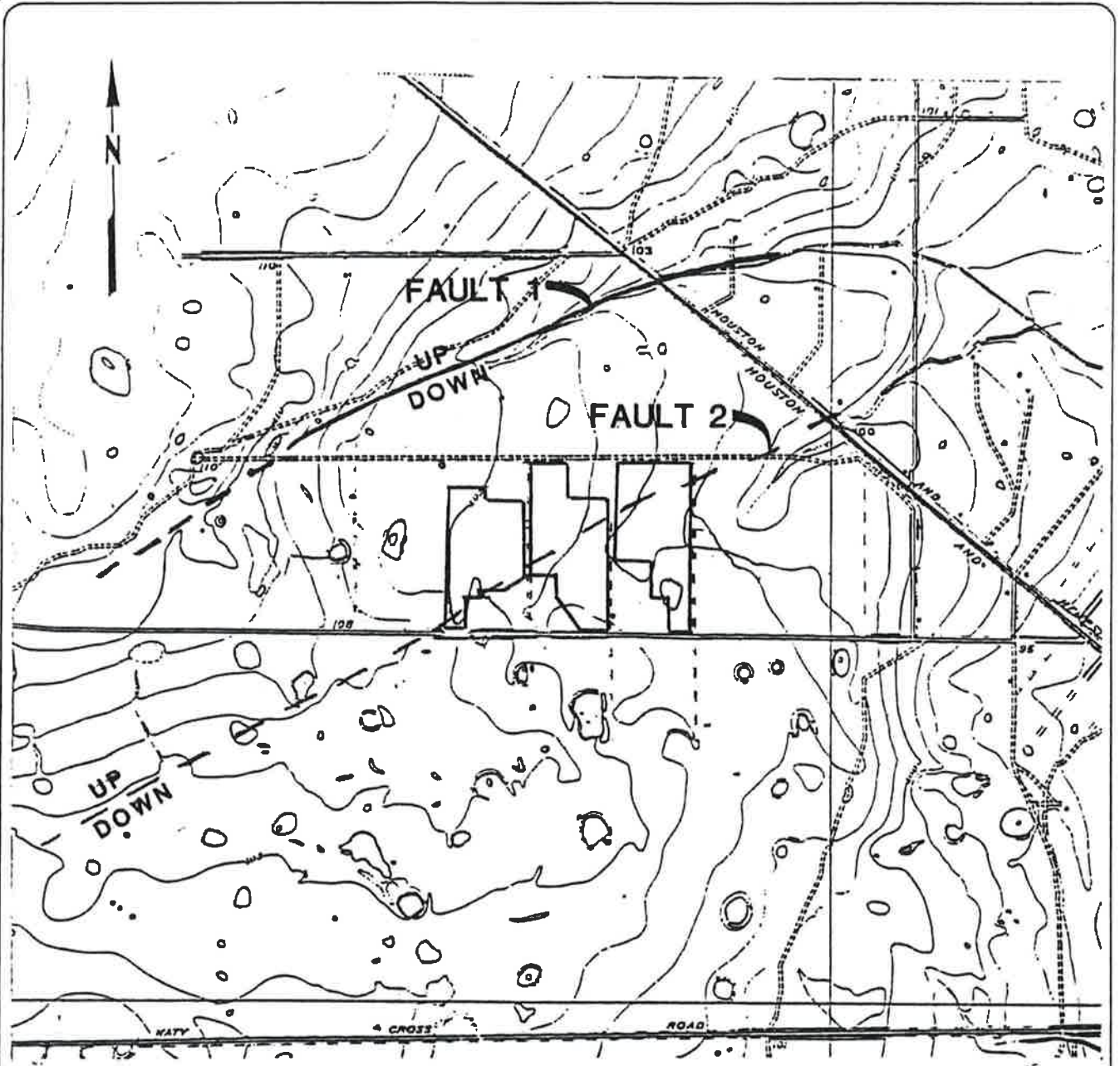

**LOCATION OF FAULTS OF VAN SICLAN, 1966  
COPIED ON U.S.G.S. TOPOGRAPHIC BASE**

FROM TURNER, COLLIE, AND BRADEN, 1966.

PROJECT NO 190-0638  
FIGURE D-1

McBride-Ratcliff and Associates, Inc.

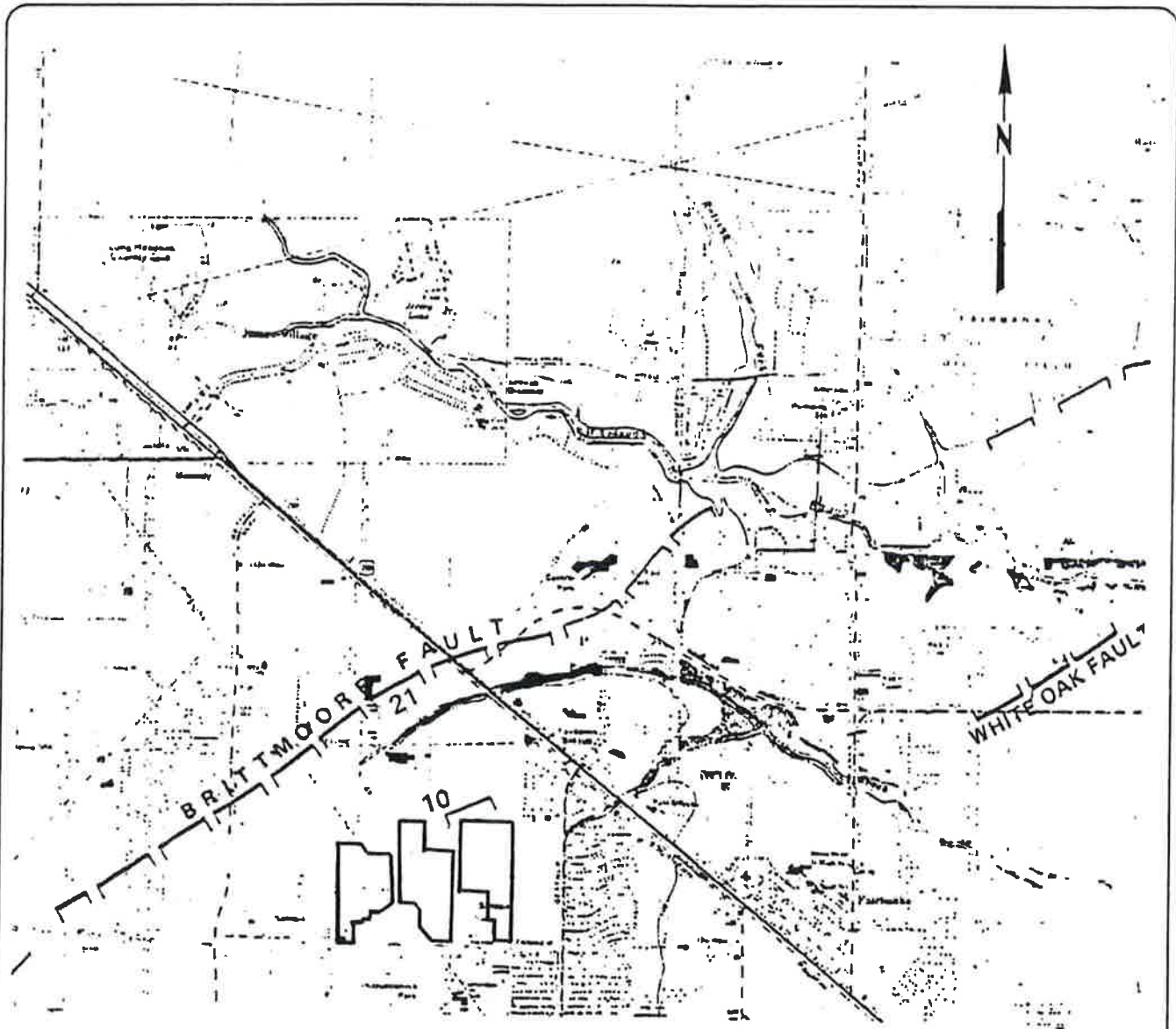

SCALE

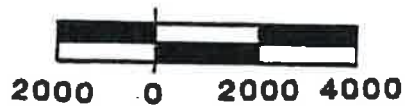

FEET

### HEUER FAULT LOCATION MAP 1979

PROJECT NO: 90-0638  
FIGURE D-2



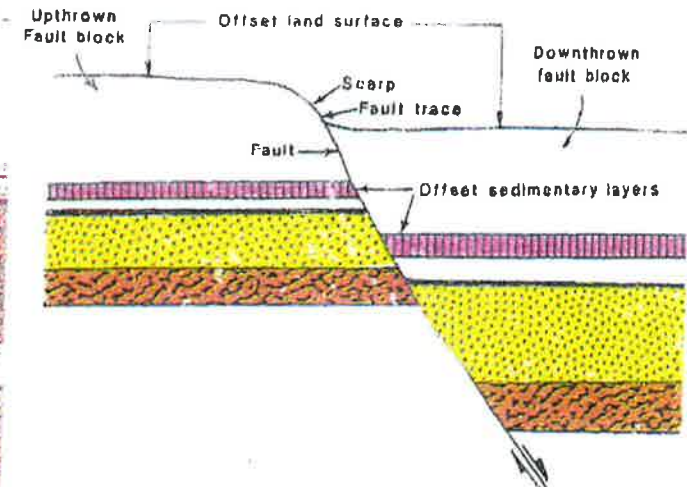
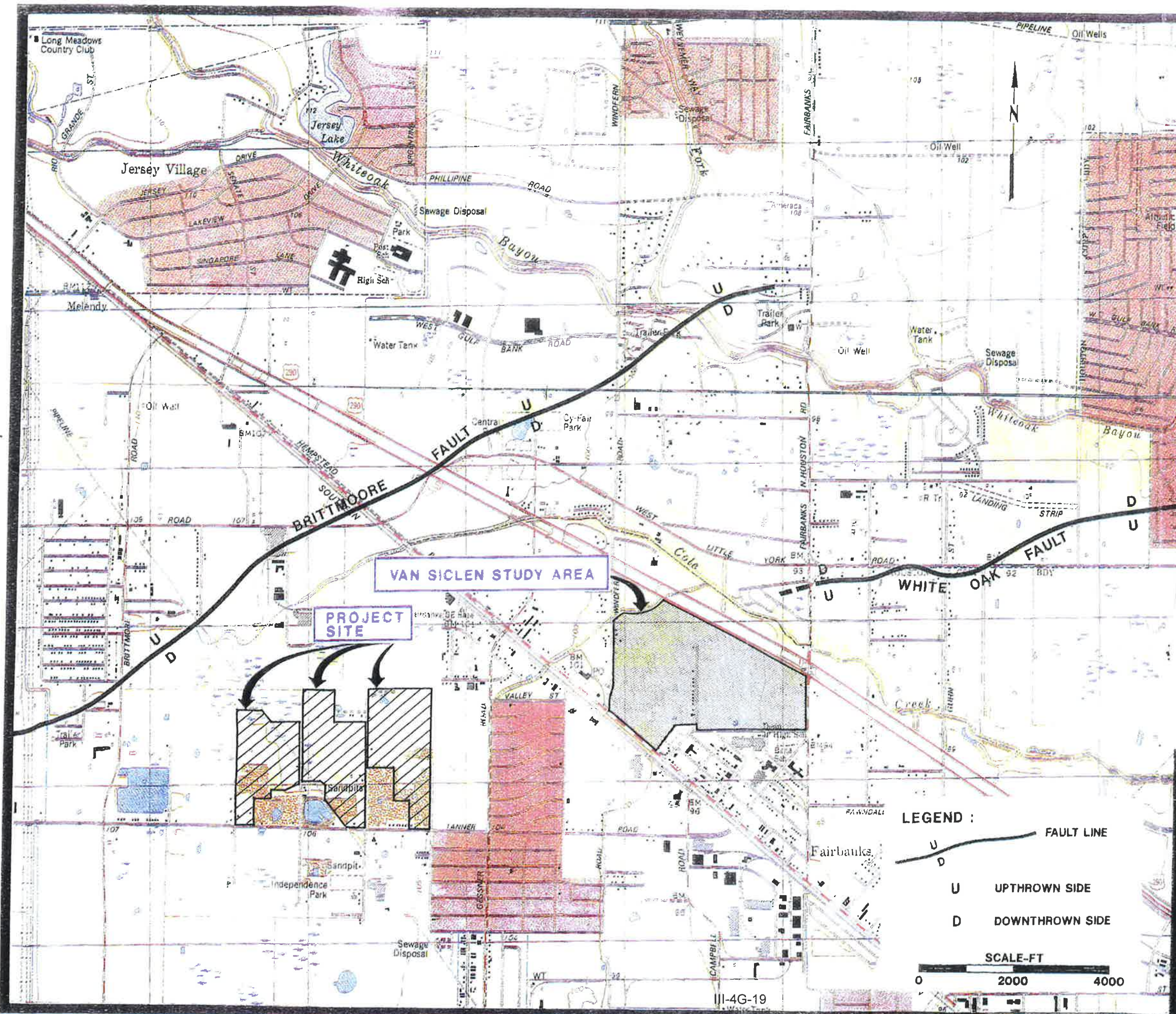

Vertical section through a hypothetical fault in the Houston area. Land surface was originally level, but has since been displaced by movement along the fault. Note thickening of sedimentary layers on the downthrown side. This indicates that faulting occurred repeatedly over a long period of time, while the sediments were being deposited. Such faults are common in the Texas Gulf Coast.

According to E.R. Verbeek, K.W. Ratzlaff and U.S. Clanton, rigid structures such as highways, runways, and building foundations, where built astride active faults, commonly display the consequences of differential vertical movement and horizontal extension. Breakage occurs as the sinking ground surface on the downthrown side no longer supports the structural load. Maximum damage normally occurs on and immediately adjacent to the fault scarp, within a zone that is typically 2-3 m wide, but which may vary in width from less than 1 m to more than 10 m. To either side of this zone, some limited fault-related failure may be seen in brittle material, but the most visible effect of fault movement here is tilting. The amount of tilt progressively decreases away from the fault scarp and is, for most faults, minor at distances of 20-30 m from the scarp. Surveying data, however, suggest that detectable amounts of tilt may be found as much as 70 m away from some faults.

Based on our observation of structural distress along the Brittmoore Fault northwest of the proposed site, the zone of surface deformation of this fault conforms to the description by Verbeek, Ratzlaff, and Clanton. It is confined to an area less than 200 ft on the downthrown block of the fault.

TEXT FROM "FAULTS IN PARTS OF NORTH-CENTRAL AND WESTERN HOUSTON METROPOLITAN AREA, TEXAS" BY E.R. VERBEEK, K.W. RATZLAFF AND U.S. CLANTON, 1979.

TOPOGRAPHIC MAP FROM U.S. GEOLOGICAL SURVEY, HEDWIG VILLAGE, TEXAS, 1982.

**HAWTHORN PARK RECLAMATION PROJECT AND RECYCLING CENTER**  
HARRIS COUNTY, TEXAS

**SANIFILL OF TEXAS, INC.**  
HOUSTON, TEXAS

 **McBride-Ratcliff and Associates, Inc.**  
A Subsidiary of The Badger Company, Inc.

SCALE NOTED	MADE CHECK	LLD/SMH LAL	DATE 10-11-93	FILE NO. 90-0638
			DATE 10-11-93	FIGURE D-3

**1980 VAN SICLEN STUDY**



# GENERAL HIGHWAY MAP HARRIS COUNTY TEXAS

PREPARED BY THE  
STATE DEPARTMENT OF HIGHWAYS  
AND PUBLIC TRANSPORTATION  
TRANSPORTATION PLANNING DIVISION  
IN COOPERATION WITH THE  
U.S. DEPARTMENT OF TRANSPORTATION  
FEDERAL HIGHWAY ADMINISTRATION

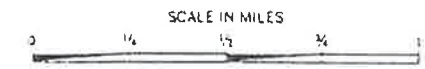

1987  
1980 CENSUS FIGURES  
HIGHWAYS REVISED TO SEPTEMBER 1, 1989

BENCHMARK LOCATION

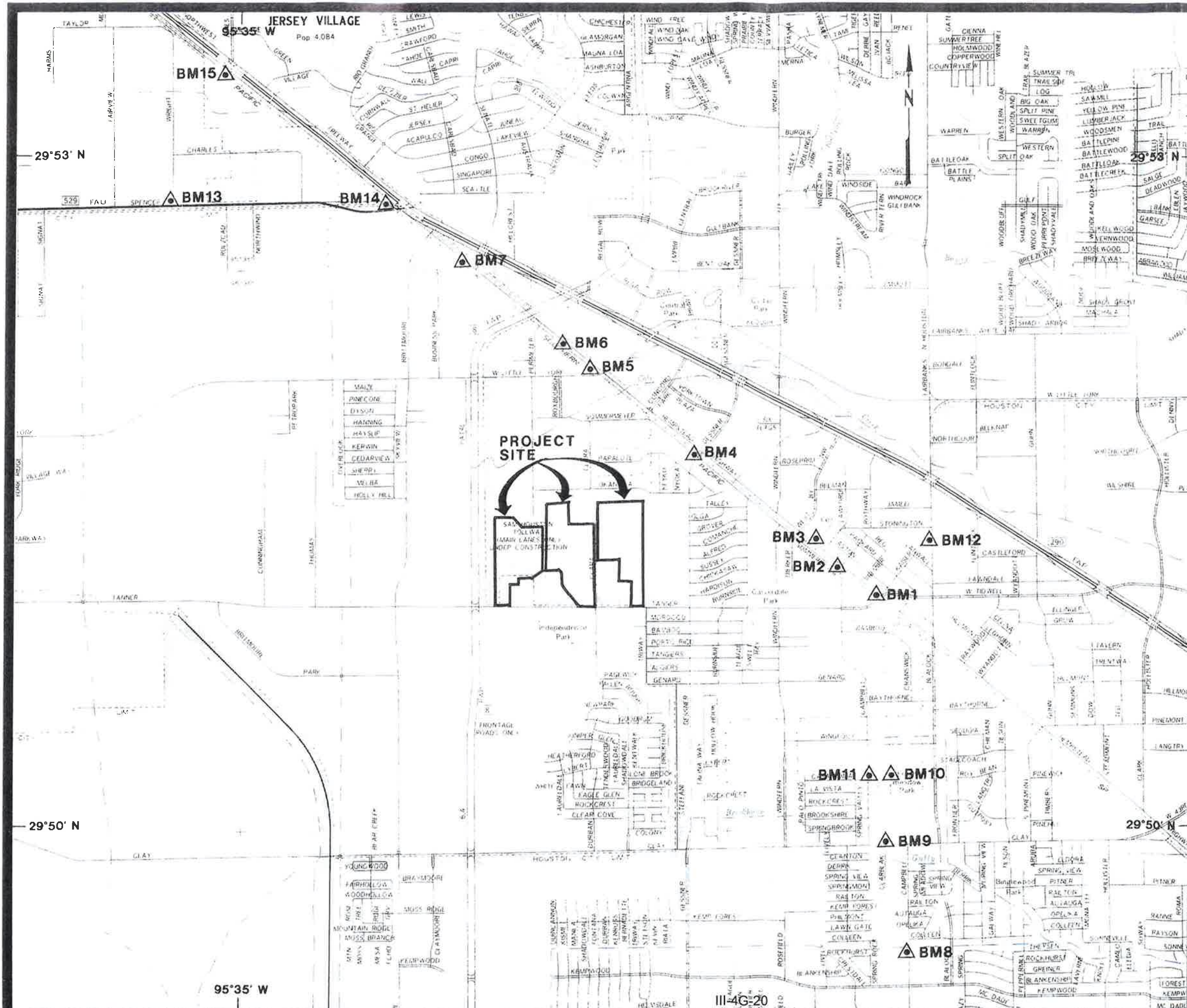

**HAWTHORN PARK RECLAMATION PROJECT  
AND RECYCLING CENTER  
HARRIS COUNTY, TEXAS**

**SANIFILL OF TEXAS, INC.  
HOUSTON, TEXAS**

 **McBride-Ratcliff and Associates, Inc.**  
A Subsidiary of The Badger Company, Inc.

SCALE NOTED	MADE CHECK	LLD JS	DATE 9-15-93	FILE NO. 90-0631
----------------	---------------	-----------	-----------------	---------------------

**BENCHMARK MAP** FIGURE  
D-4



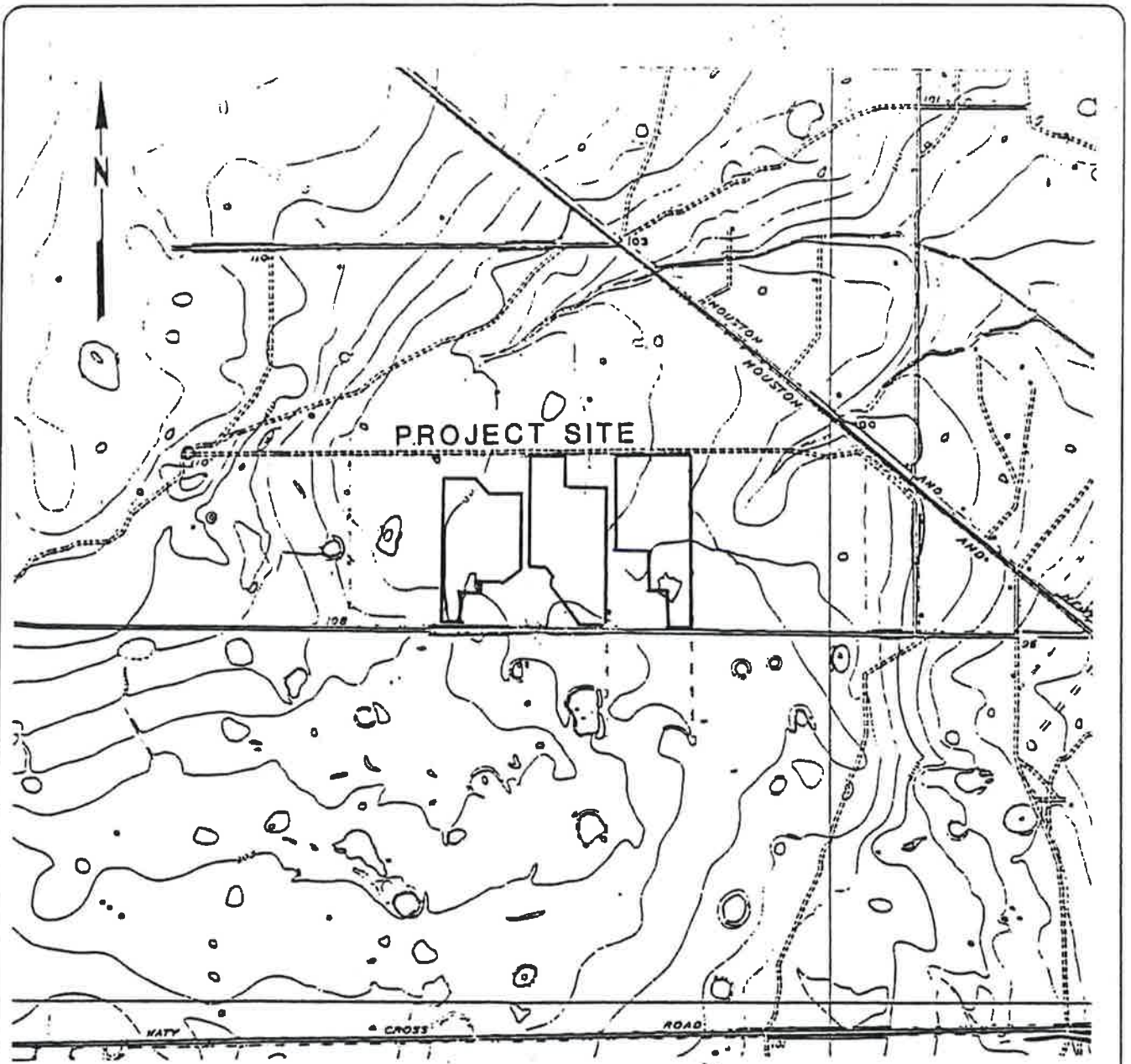

SCALE



**SITE VICINITY MAP**  
**FROM U.S. GEOLOGICAL SURVEY 1918 HILLENDAHL QUADRANGLE**

(1-FT CONTOUR INTERVAL)

III-4G-21

**PROJECT NO. 90-0638**  
**FIGURE D-5**

McBride-Ratcliff and Associates, Inc.



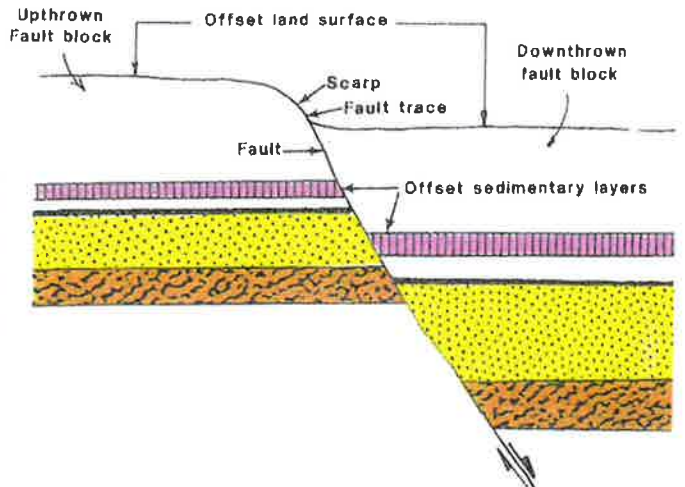
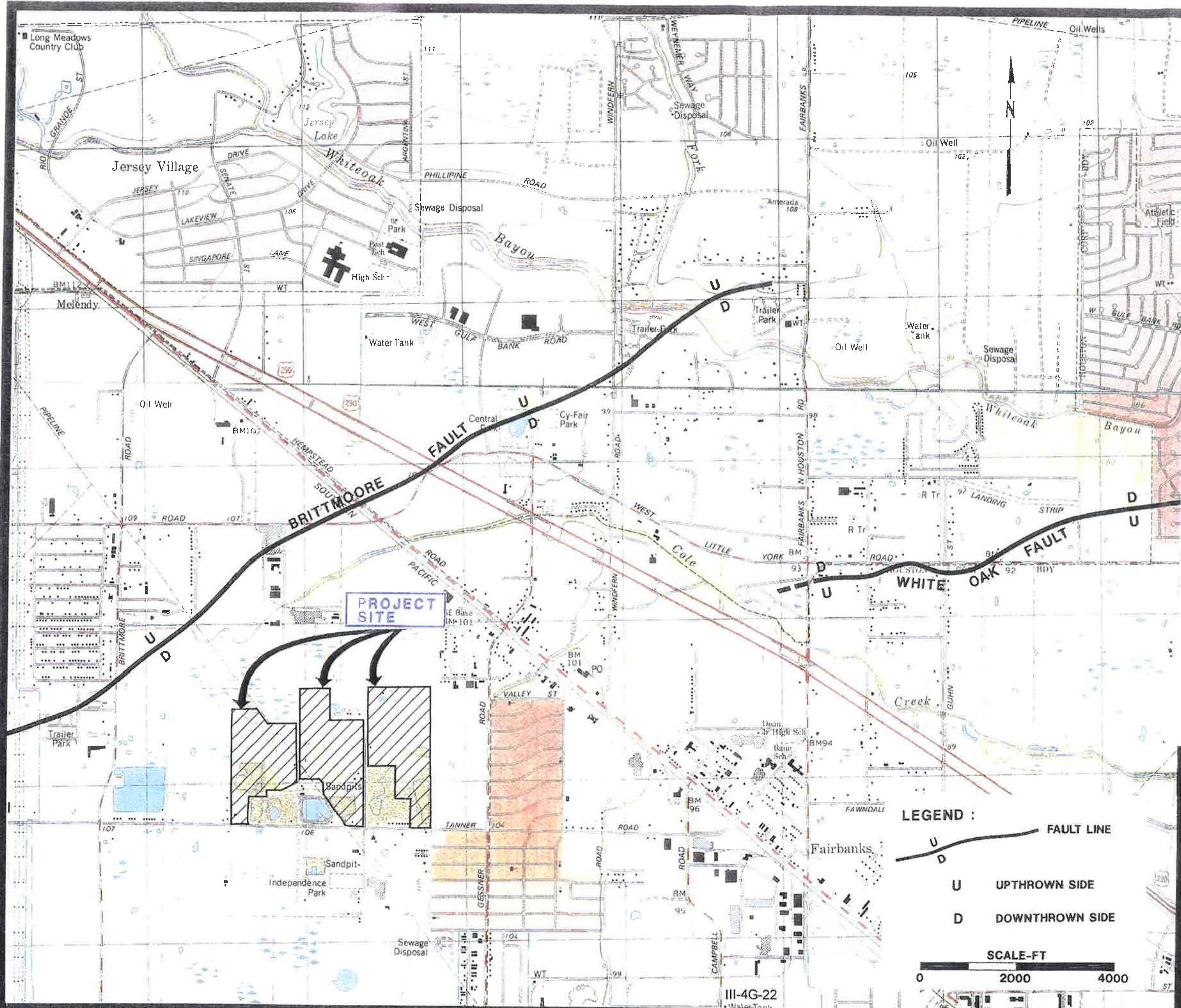

Vertical section through a hypothetical fault in the Houston area. Land surface was originally level, but has since been displaced by movement along the fault. Note thickening of sedimentary layers on the downthrown side. This indicates that faulting occurred repeatedly over a long period of time, while the sediments were being deposited. Such faults are common in the Texas Gulf Coast.

According to E.R. Verbeek, K.W. Ratzlaff and U.S. Clanton, rigid structures such as highways, runways, and building foundations, where built astride active faults, commonly display the consequences of differential vertical movement and horizontal extension. Breakage occurs as the sinking ground surface on the downthrown side no longer supports the structural load. Maximum damage normally occurs on and immediately adjacent to the fault scarp, within a zone that is typically 2-3 m wide, but which may vary in width from less than 1 m to more than 10 m. To either side of this zone, some limited fault-related failure may be seen in brittle material, but the most visible effect of fault movement here is tilting. The amount of tilt progressively decreases away from the fault scarp and is, for most faults, minor at distances of 20-30 m from the scarp. Surveying data, however, suggest that detectable amounts of tilt may be found as much as 70 m away from some faults.

Based on our observation of structural distress along the Brittmoore Fault northwest of the proposed site, the zone of surface deformation of this fault conforms to the description by Verbeek, Ratzlaff, and Clanton. It is confined to an area less than 200 ft on the downthrown block of the fault.

TEXT FROM "FAULTS IN PARTS OF NORTH-CENTRAL AND WESTERN HOUSTON METROPOLITAN AREA, TEXAS" BY E.R. VERBEEK, K.W. RATZLAFF AND U.S. CLANTON, 1979.

TOPOGRAPHIC MAP FROM U.S. GEOLOGICAL SURVEY, HEDWIG VILLAGE, TEXAS, 1982.

**HAWTHORN PARK RECLAMATION PROJECT AND RECYCLING CENTER**  
HARRIS COUNTY, TEXAS

**SANIFILL OF TEXAS, INC.**  
HOUSTON, TEXAS

 **McBride-Ratcliff and Associates, Inc.**  
A Subsidiary of The Badger Company, Inc.

SCALE NOTED	MADE CHECK	LLD/SMH LAL	DATE 10-11-93 DATE 10-11-93	FILE NO. 90-0638
-------------	------------	----------------	--------------------------------	---------------------

**FAULT MAP** FIGURE D-6



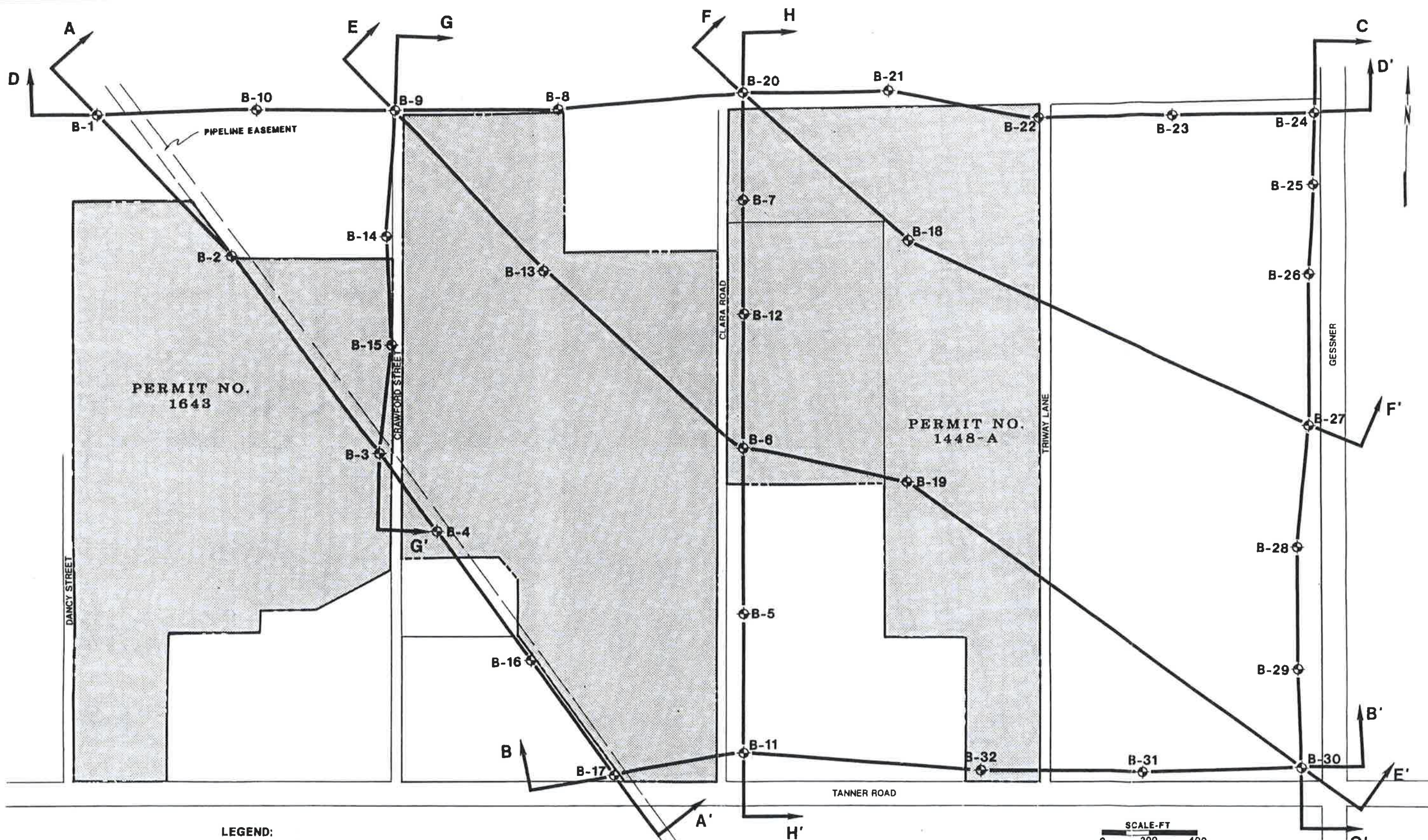

**LEGEND:**

- ⊕ TEST HOLE LOCATION
- A — A' CROSS-SECTION ALIGNMENT
- PROPOSED PERMIT BOUNDARY



**HAWTHORN PARK RECLAMATION PROJECT  
AND RECYCLING CENTER**  
HARRIS COUNTY, TEXAS

---

**SANIFILL OF TEXAS, INC.**  
HOUSTON, TEXAS

 **McBride-Ratcliff and Associates, Inc.**  
A Subsidiary of The Badger Company, Inc.

SCALE NOTED	MADE CHECK	LLD/SMH LAL	DATE 10-11-93	FILE NO. 90-0838
TESTHOLE LOCATIONS				FIGURE D-7



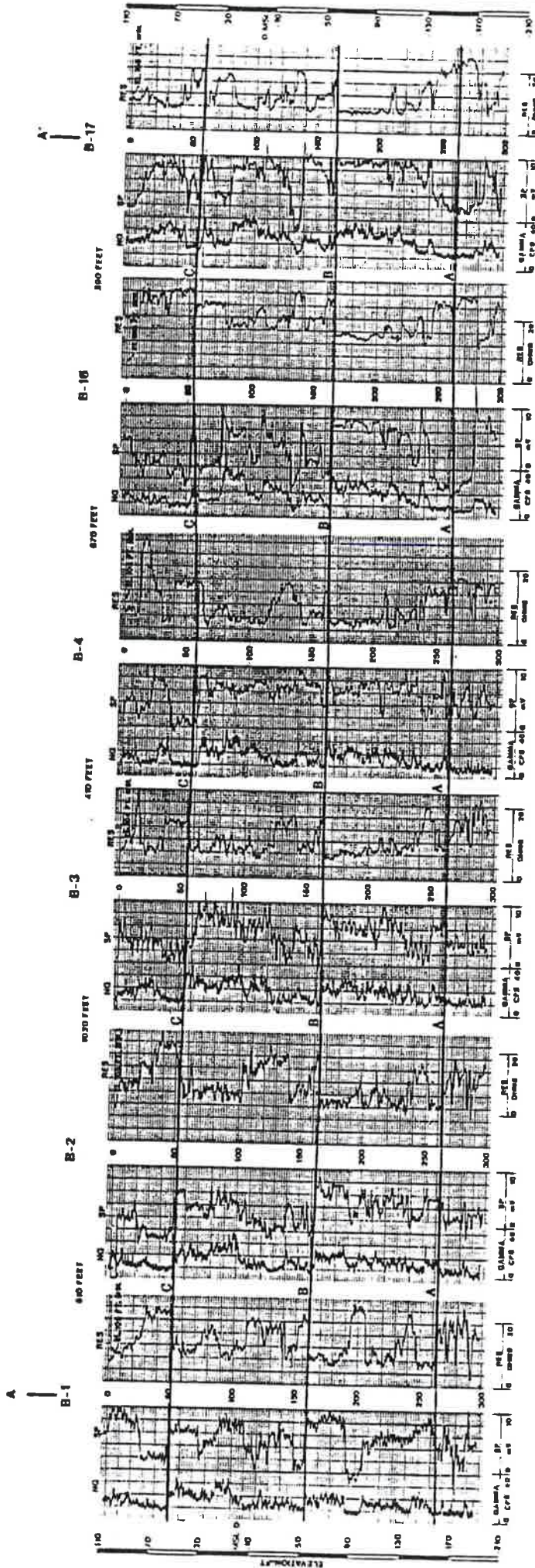

**HAWTHORN PARK RECLAMATION PROJECT AND  
RECYCLING CENTER**  
HARRIS COUNTY, TEXAS

SANIFILL OF TEXAS, INC.  
HOUSTON, TEXAS

**McBride-Ratcliff and Associates, Inc.**  
Geotechnical Consultants  
Houston, Texas

SCALE	1/17/83	DATE	1/17/83	FILE NO.	91-0838
NOTES	1/17/83	DATE	1/17/83	FILE NO.	91-0838

CROSS-SECTION A-A'  
D-8

- LEGEND:**
- NG = NATURAL GAMMA RAY
  - SP = SPONTANEOUS POTENTIAL
  - RES = SINGLE POINT RESISTANCE
  - A---A' = DESIGNATES CROSS-SECTION
  - DESIGNATES INTERPRETED
  - MARKER BEDS

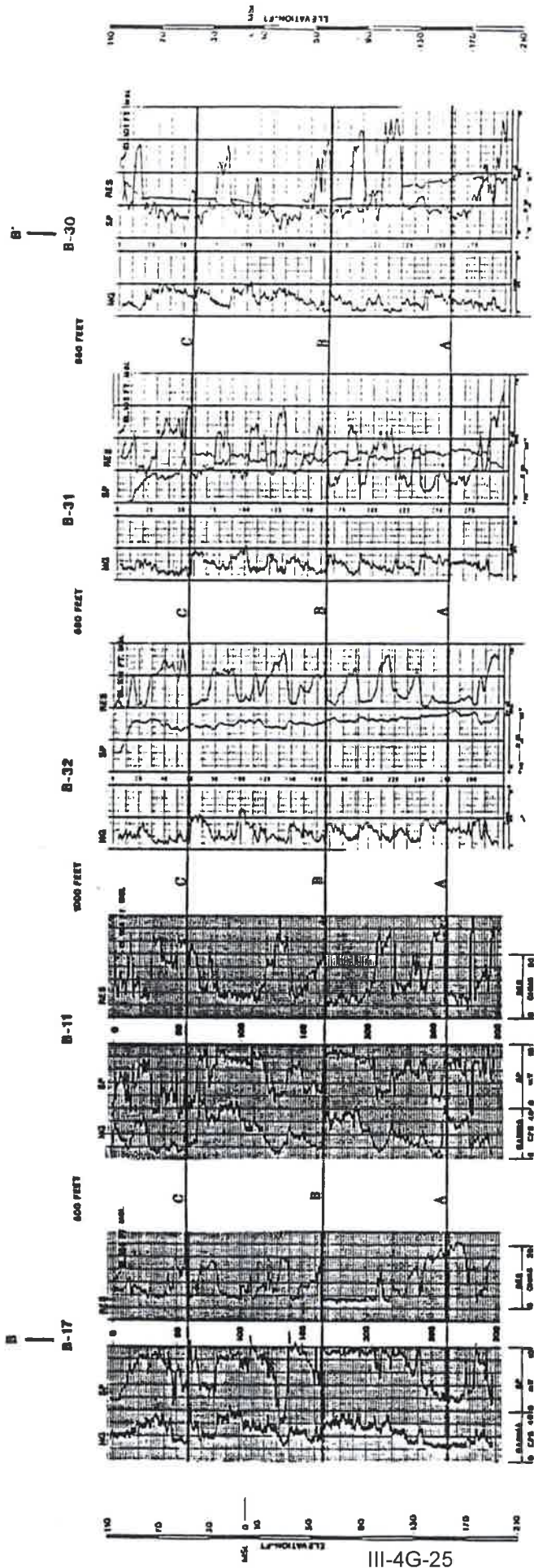

**LEGEND:**

- MG • NATURAL GAMMA RAY
- SP • SPONTANEOUS POTENTIAL
- RES • SINGLE POINT RESISTANCE
- A---A' • DESIGNATES CROSS-SECTION
- DESIGNATES INTERPRETED MARKER BEDS

**HAWTHORN PARK RECLAMATION PROJECT AND RECYCLING CENTER**  
 HARRIS COUNTY, TEXAS

**SANIFILL OF TEXAS, INC.**  
 HOUSTON, TEXAS

**McBride-Ratcliff and Associates, Inc.**  
 Geotechnical Consultants  
 HOUSTON, TEXAS

SCALE	DATE	BY	1/17/02	FILE NO.
NOTED	CHG	TY	010	91-0038
			1/18/02	FIGURE
				D-9

CROSS-SECTION B-B'



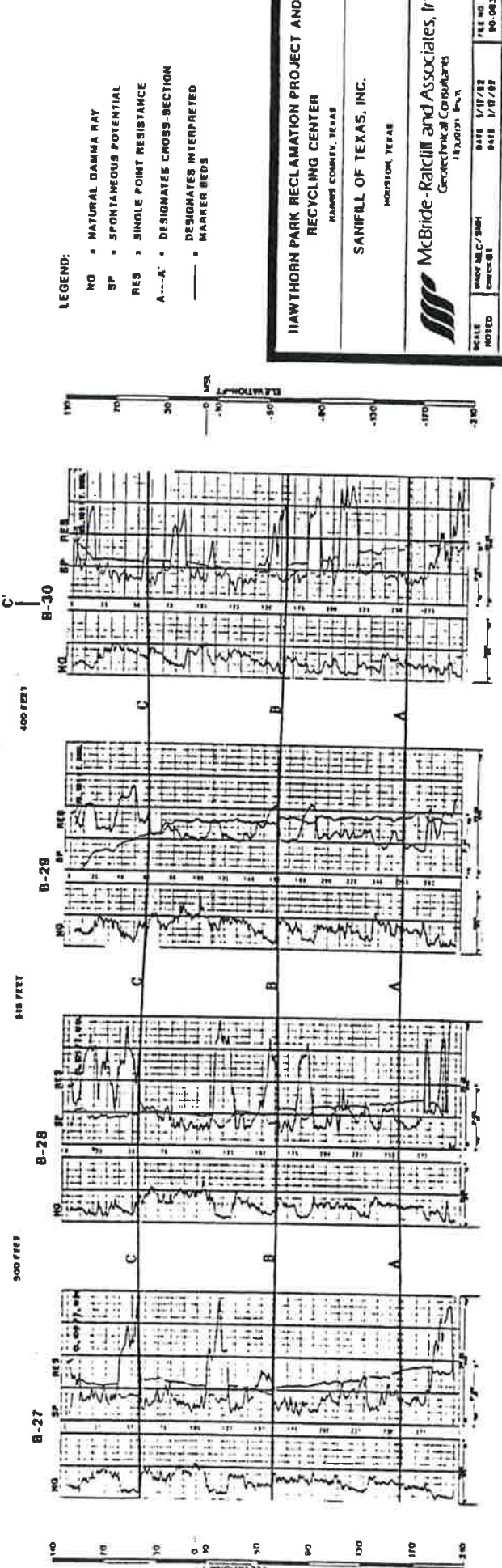
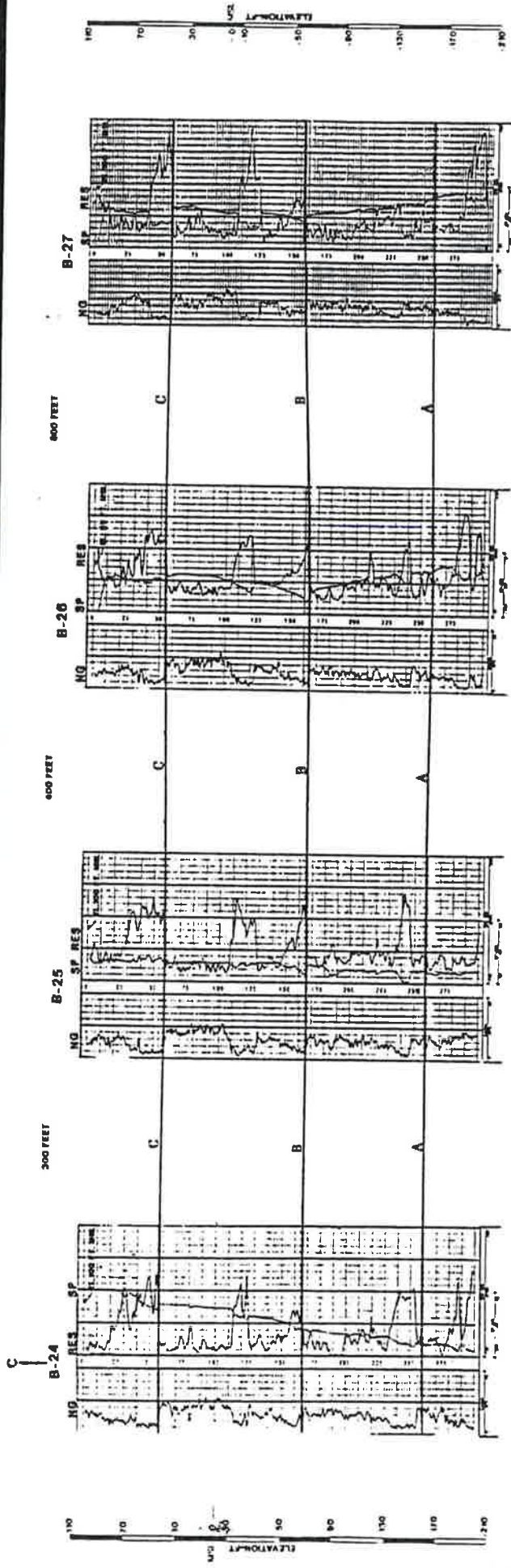

**LEGEND:**  
 NG = NATURAL GAMMA RAY  
 SP = SPONTANEOUS POTENTIAL  
 RES = SINGLE POINT RESISTANCE  
 A---A' = DESIGNATES CROSS-SECTION  
 ————— DESIGNATES INTERPRETED  
 \* MARKER BEDS

**HAWTHORN PARK RECLAMATION PROJECT AND RECYCLING CENTER**  
 HARRIS COUNTY, TEXAS

**SANIFILL OF TEXAS, INC.**  
 HOUSTON, TEXAS

**McBride-Raitliff and Associates, Inc.**  
 Geotechnical Consultants  
 Houston, Texas

SCALE	DATE	FILE NO.
NOTED	1/11/82	80-0638
BY: M.C./S.M.H.	DATE	PROJECT
DEC 81	1/10/82	D-10

**CROSS-SECTION C-C'**



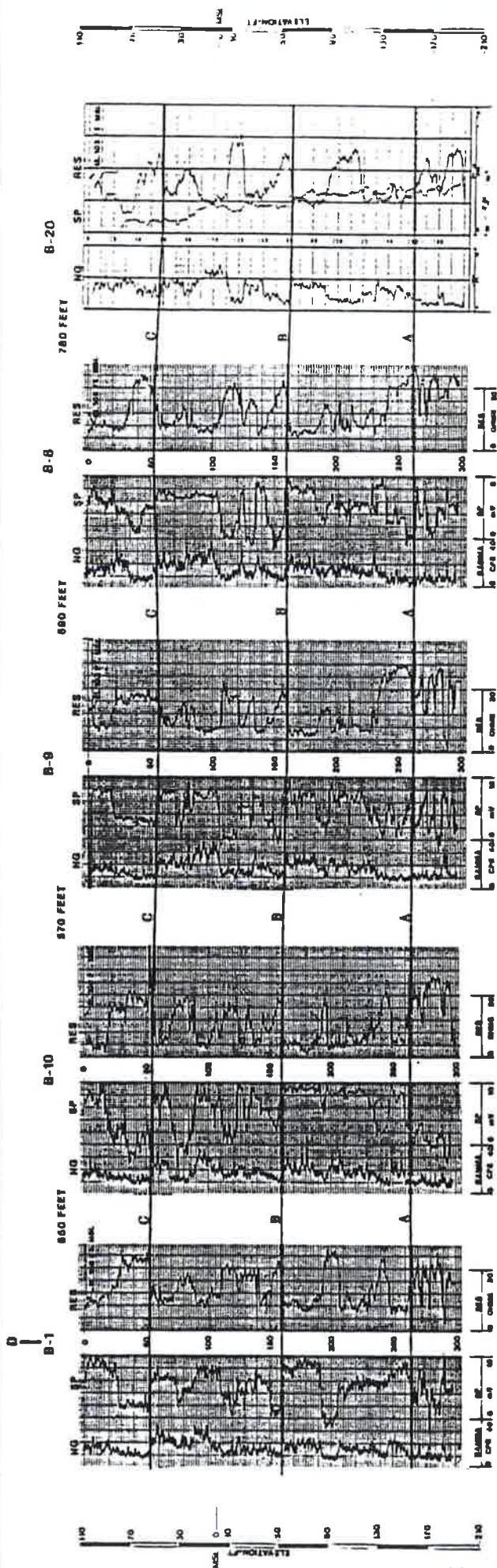

LEGEND:

- MG = NATURAL GAMMA RAY
- SP = SPONTANEOUS POTENTIAL
- RES = SINGLE POINT RESISTANCE
- A---A' = DESIGNATES CROSS-SECTION
- = DESIGNATES INTERPRETED MARKER BEDS

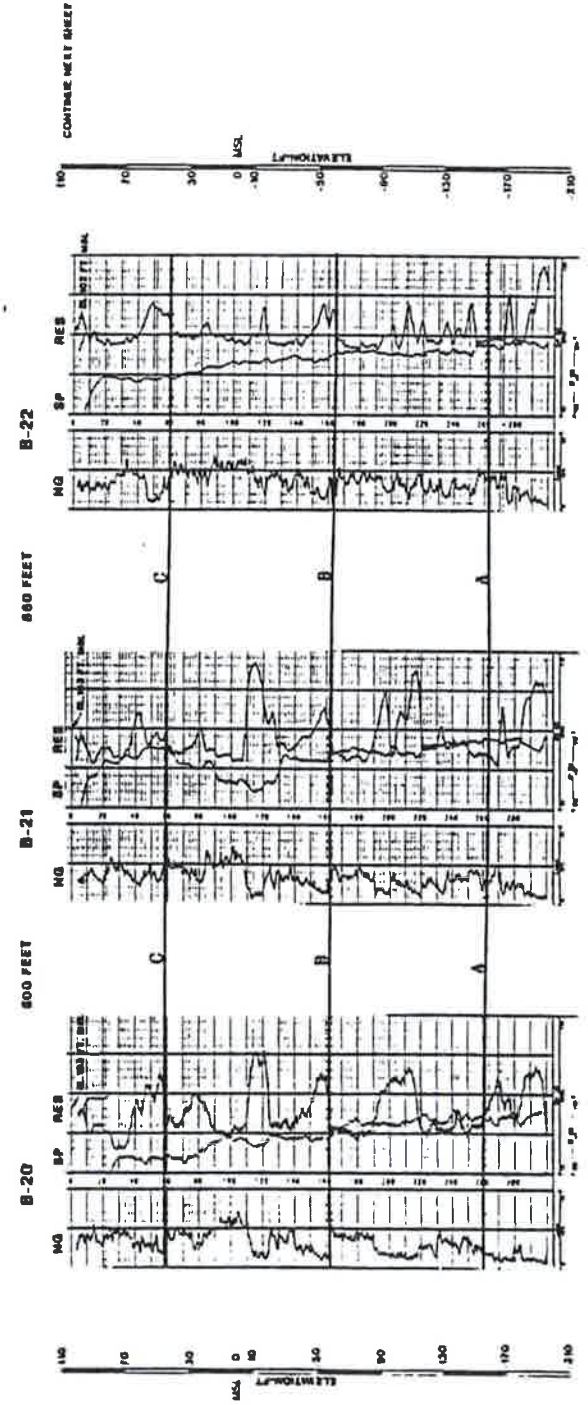

**HAWTHORN PARK RECLAMATION PROJECT AND RECYCLING CENTER**  
 HARRIS COUNTY, TEXAS  
**SANFILL OF TEXAS, INC.**  
 HOUSTON, TEXAS

  
**McBride-Ratcliff and Associates, Inc.**  
 Geotechnical Consultants  
 14300 Katy, Texas

BOCAS	DATE	BY	DATE	FILE NO.
10/11/82	10/11/82	SMH	10/11/82	90 0828
REVISED	CHECKED	BY	DATE	FIGURE
				D-11

**CROSS-SECTION D-D'**



CONTINUE FROM PREVIOUS SHEET

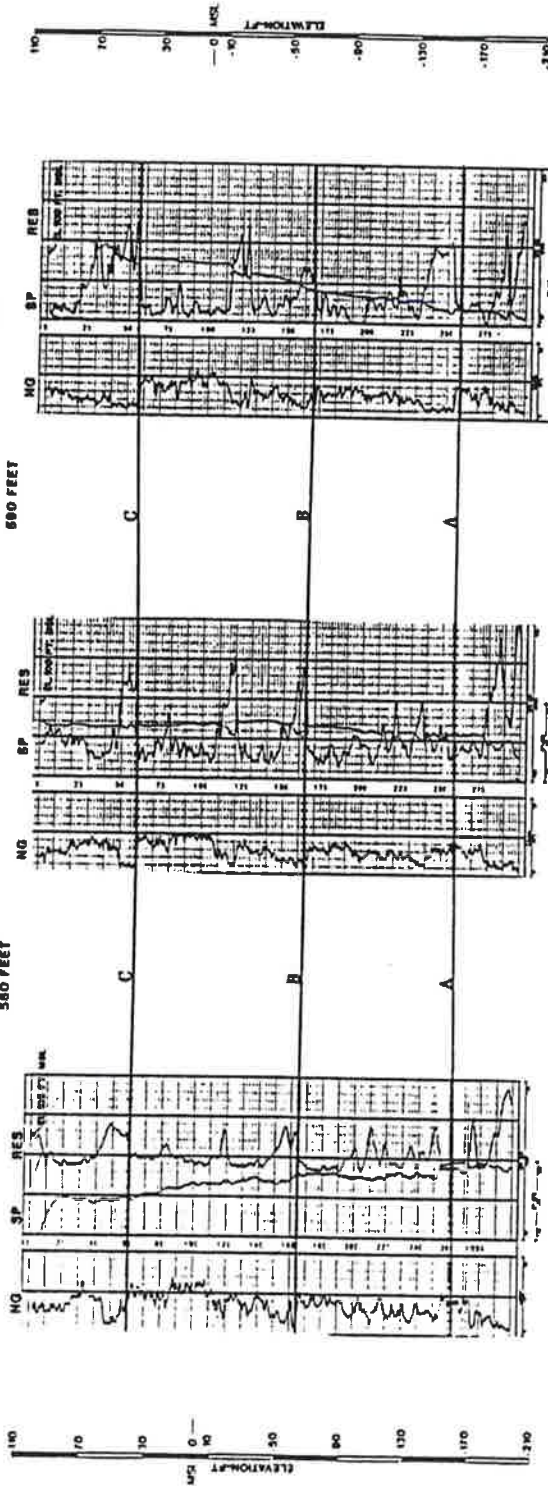

**HAWTHORN PARK RECLAMATION PROJECT AND RECYCLING CENTER**  
 HARRIS COUNTY, TEXAS

SANFILL OF TEXAS, INC.  
 HOUSTON, TEXAS

**McBride-Ratcliff and Associates, Inc.**  
 Geotechnical Consultants  
 Houston, Texas

SCALE	DATE	BY	NO.
NOTED	1/17/88	8418	86 0858
	0-100 T.I.	8418	1/17/88

CROSS-SECTION D-D'

D-12

**LEGEND:**

- NG • NATURAL GAMMA RAY
- SP • SPONTANEOUS POTENTIAL
- RES • SINGLE POINT RESISTANCE
- A---A' • DESIGNATES CROSS-SECTION
- ..... • DENOTES INTERPRETED
- • MARKER BEDS

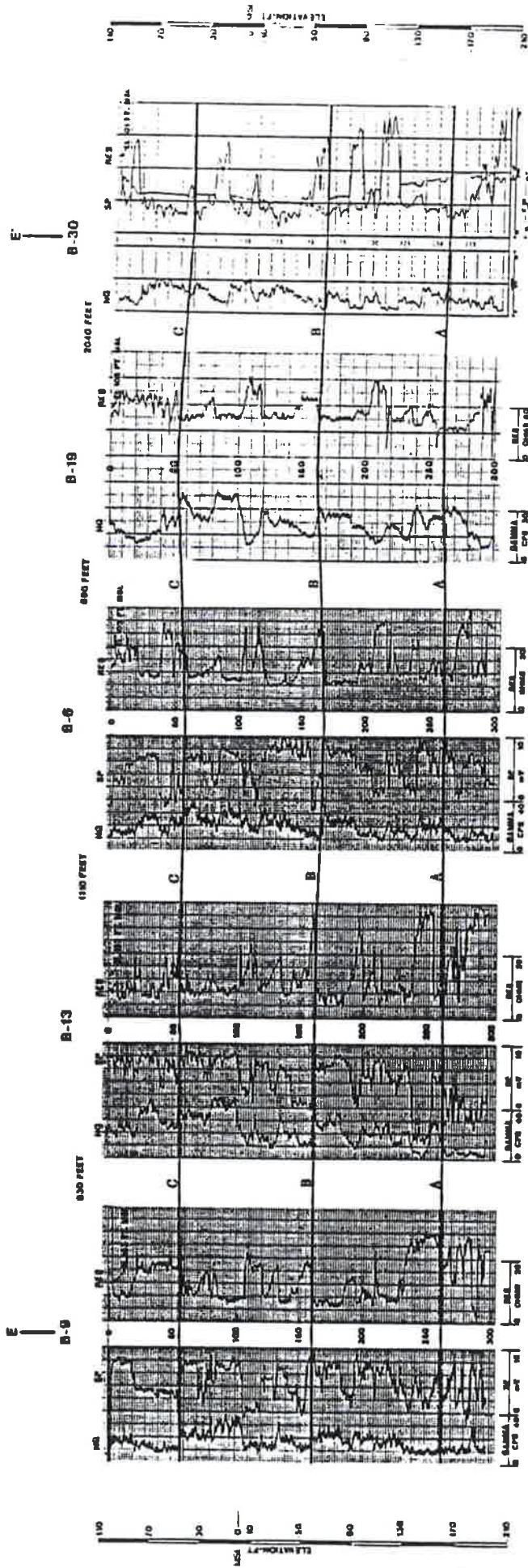

**NAWTHORN PARK RECLAMATION PROJECT AND  
RECYCLING CENTER**  
HARRIS COUNTY, TEXAS

**SANIFILL OF TEXAS, INC.**  
HOUSTON, TEXAS



SCALE	DATE	FILE NO.
NOTED	1/17/82	81 0638
DATE	1/17/82	FIGURE
1/17/82		D-13

**LEGEND:**

- MG \* NATURAL GAMMA RAY
- SP \* SPONTANEOUS POTENTIAL
- RES \* SINGLE POINT RESISTANCE
- A---A' \* DESIGNATED CROSS-SECTION
- \* DESIGNATED INTERPRETED MARKER BEDS



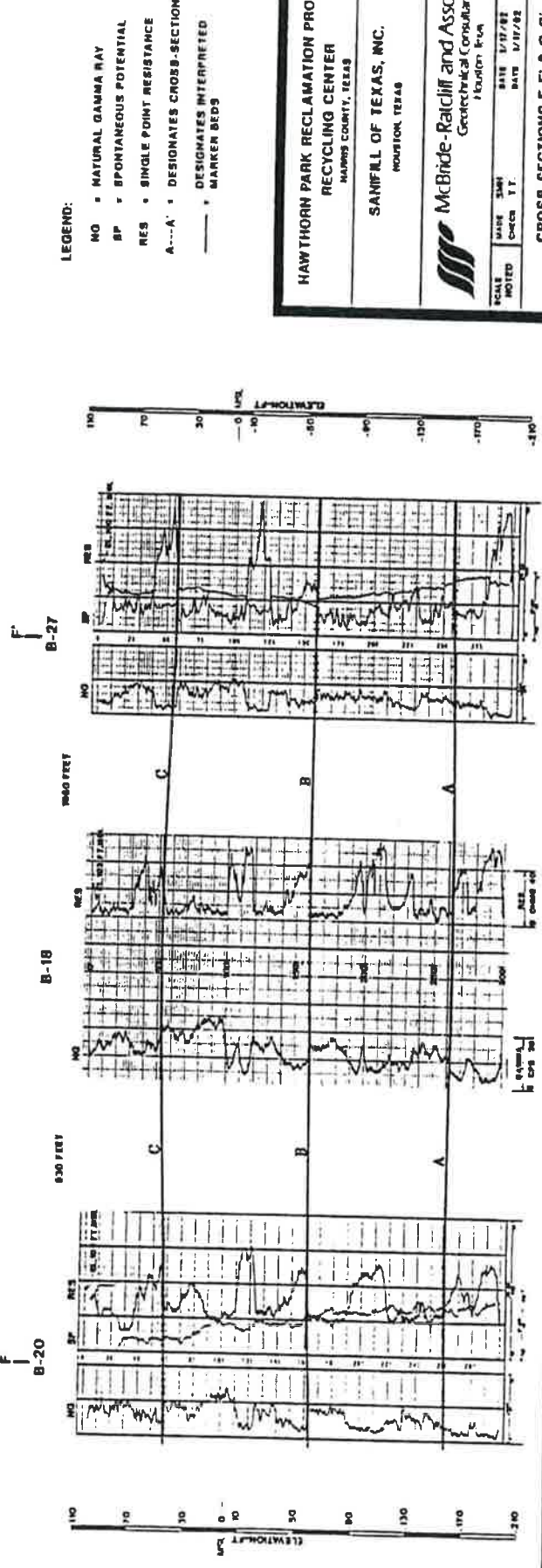
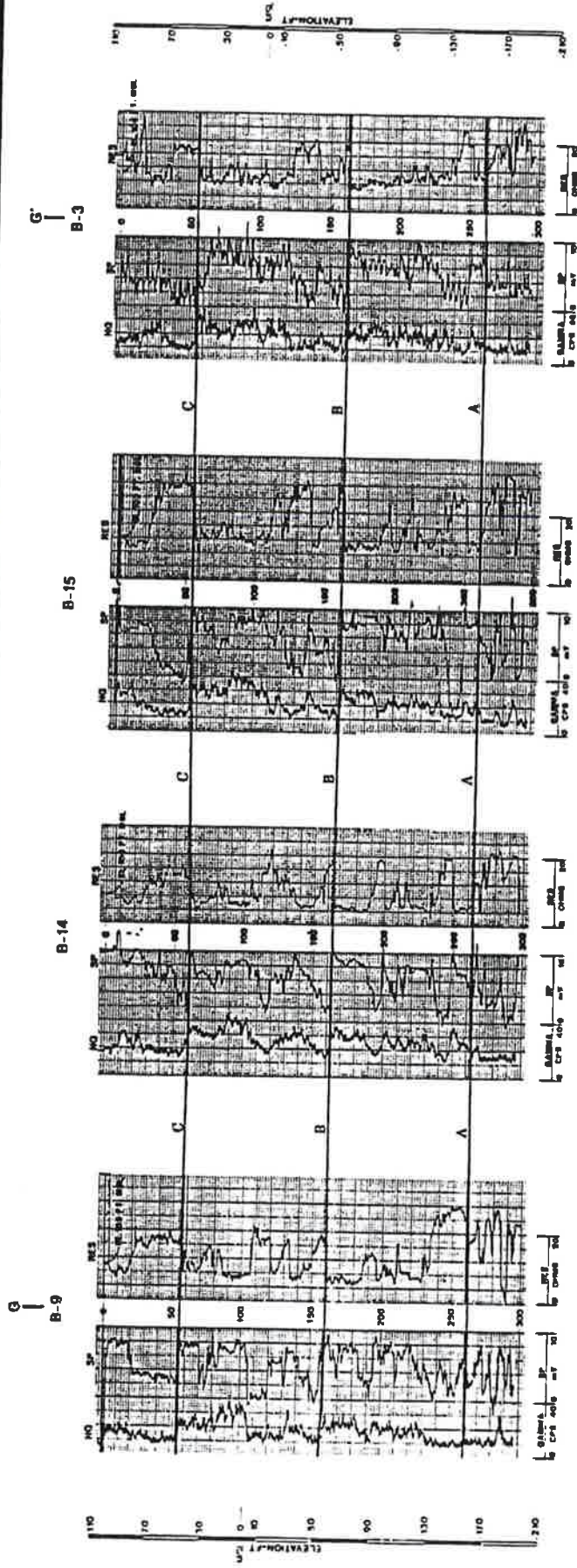

**LEGEND:**

- NO = NATURAL GAMMA RAY
- SP = SPONTANEOUS POTENTIAL
- RES = SINGLE POINT RESISTANCE
- A---A' = DESIGNATES CROSS-SECTION
- = DESIGNATES INTERPRETED
- = MARKER BEDS

**HAWTHORN PARK RECLAMATION PROJECT AND  
RECYCLING CENTER**  
HARRIS COUNTY, TEXAS

**SANFALL OF TEXAS, INC.**  
HOUSTON, TEXAS

McBride-Ratcliff and Associates, Inc.  
Geotechnical Consultants  
Houston, Texas

SCALE NOTED	DATE CHECKED	DATE DATE	189 NO. 95-0838
		1/17/82	1/17/82
			FRAME

**CROSS-SECTIONS F-F' & G-G'**



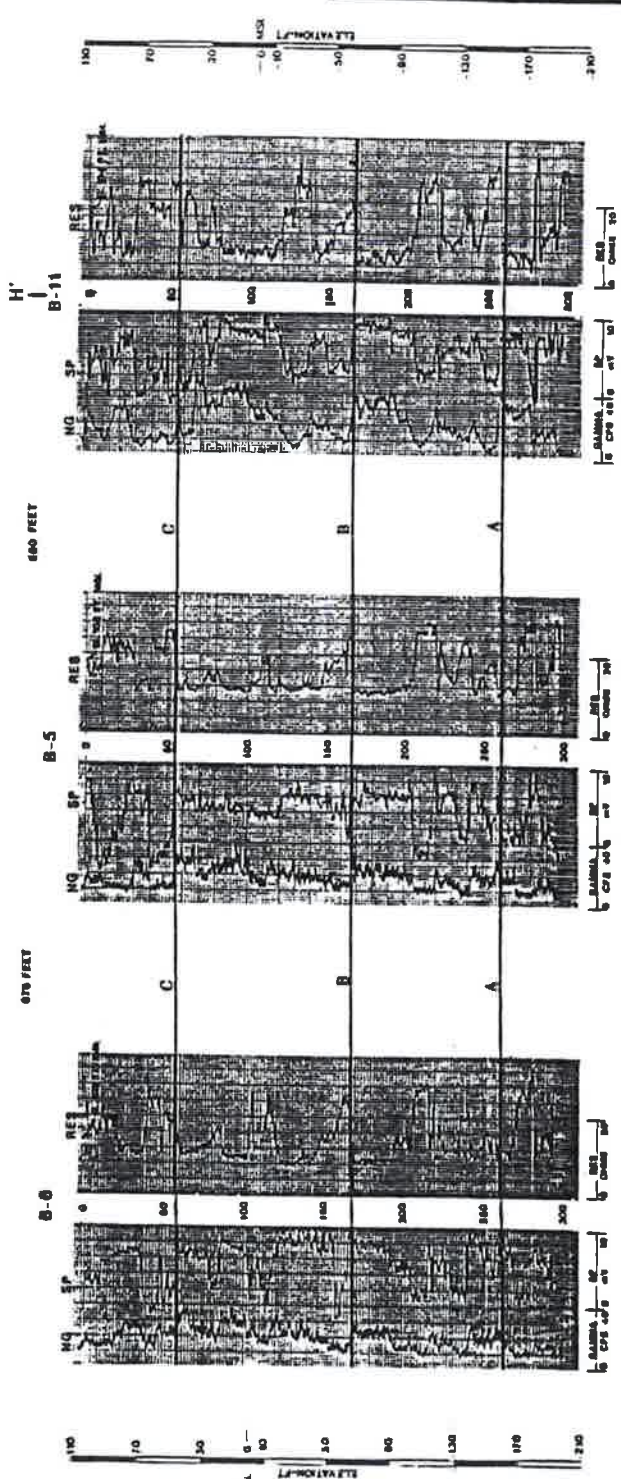
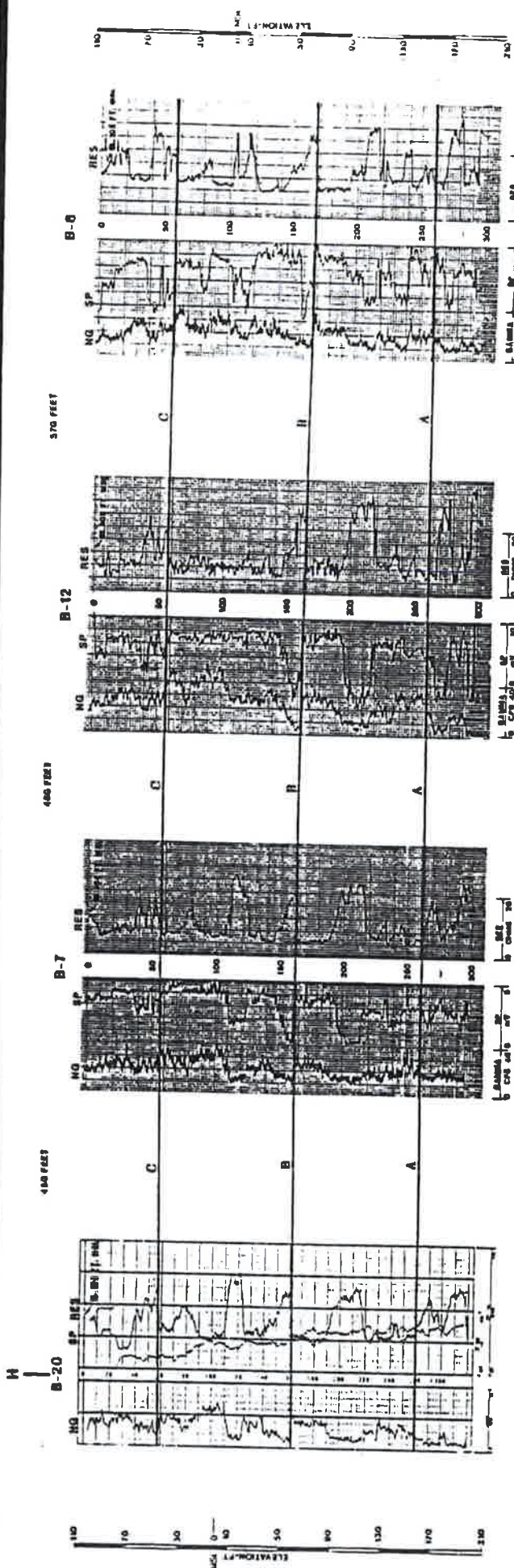

LEGEND:

NG = NATURAL GAMMA RAY

SP = SPONTANEOUS POTENTIAL

RES = SINGLE POINT RESISTANCE

A---A' : DESIGNATES CROSS SECTION

— : DESIGNATES INTERPRETED

— : MARKER BEDS

HAWTHORN PARK RECLAMATION PROJECT AND RECYCLING CENTER  
HARRIS COUNTY, TEXAS

SANFILL OF TEXAS, INC.  
HOUSTON, TEXAS

McBride-Ratcliff and Associates, Inc.  
Geophysical Consultants  
HOUSTON, TEXAS

SCALE	MADE IN U.S.A.	DATE	FIG. NO.
NOTED	CANADA	1/17/83	80 08.06
		5-11	1/17/83

CROSS-SECTION H-H'



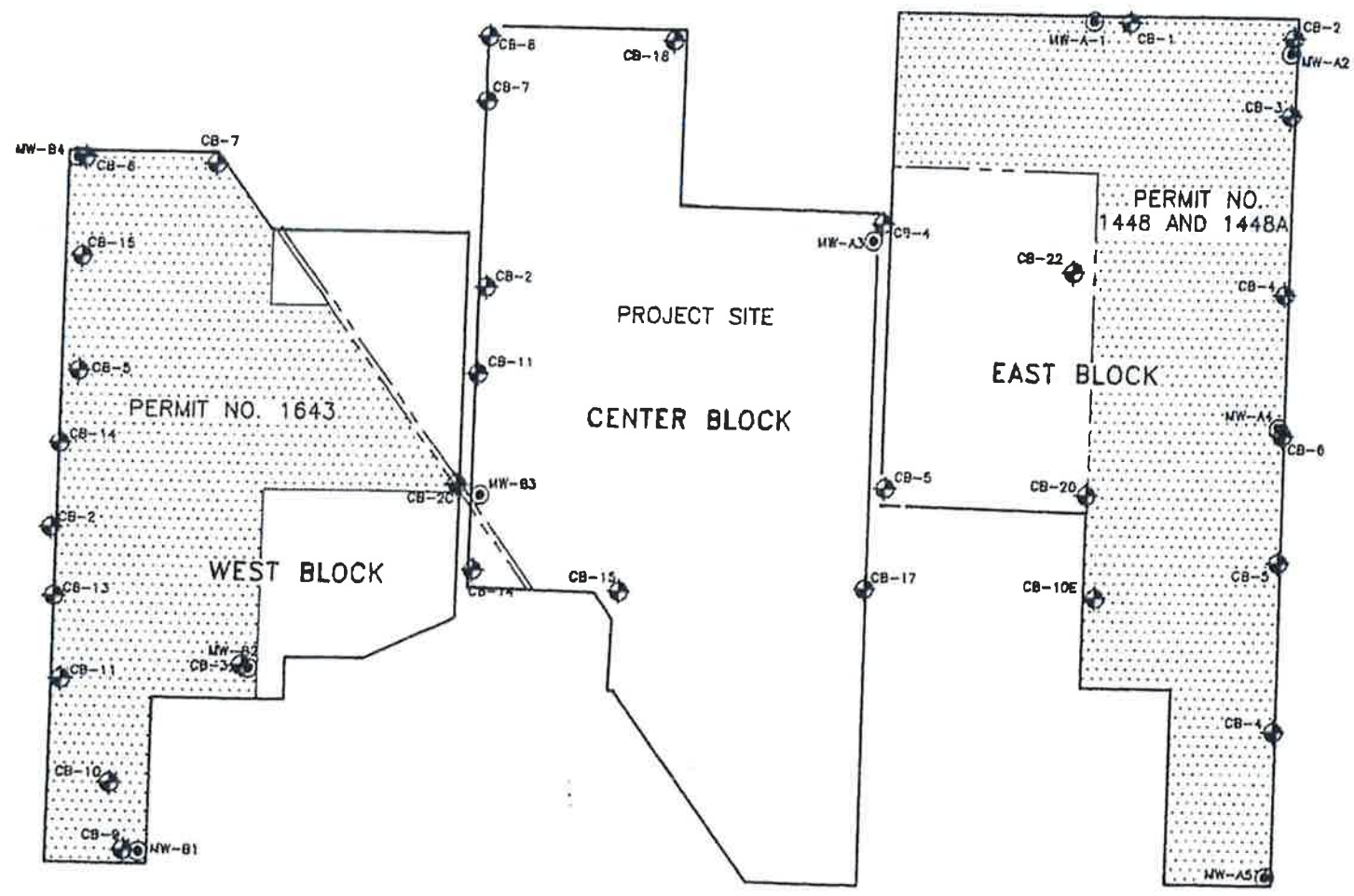

FIGURE D-15

**HAWTHORN PARK LANDFILL  
APPENDIX III-4H  
PREVIOUS PERMIT DATA**

**BORING LOCATION MAP**



**LEGEND:**

-  PROPOSED PERMIT BOUNDARY
-  EXISTING PERMITTED AREAS
-  SOIL BORING
-  EXISTING MONITORING WELL

**NOTES:**

1. MONITORING WELLS MW-A1, A2, A3, A4, AND A5 ARE MONITORING PERMIT NO. 1448 AND 1448A.
2. MONITORING WELLS MW-B1, B2, B3, AND B4 ARE MONITORING PERMIT NO. 1643.





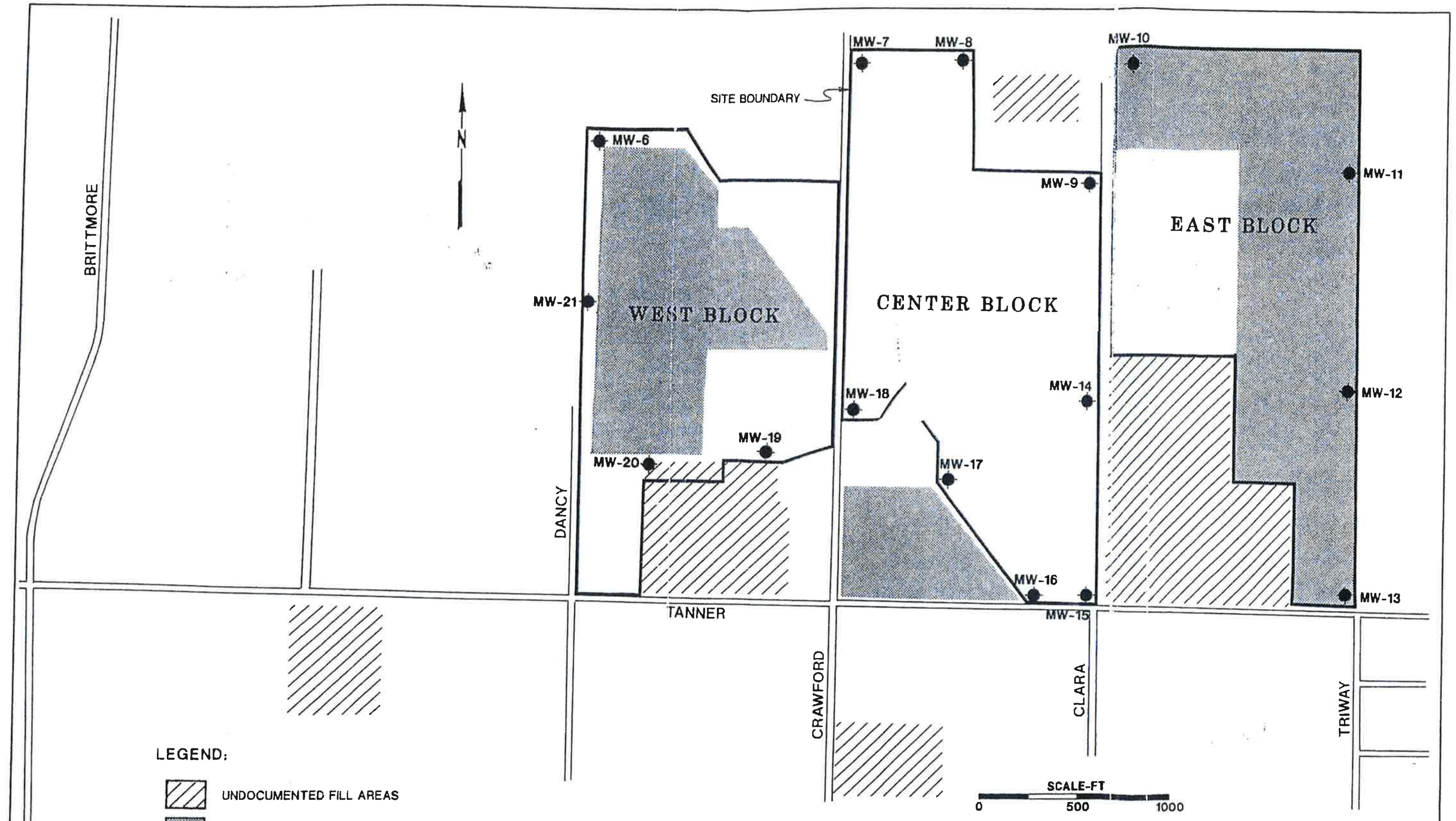

<b>HAWTHORN PARK RECLAMATION PROJECT AND RECYCLING CENTER</b> HARRIS COUNTY, TEXAS			
<b>SANIFILL OF TEXAS, INC.</b> HOUSTON, TEXAS			
 <b>McBride-Ratcliff and Associates, Inc.</b> A Subsidiary of The Badger Company, Inc.			
SCALE	DRAWN MLC/JRR	DATE 8-14-93	FILE NO.
NOTED	CHECK JRL	DATE 8-14-93	<b>90-0638</b>
<b>VICINITY BORING LOCATIONS</b>			FIGURE <b>11B</b>





**LEGEND:**

-  UNDOCUMENTED FILL AREAS
-  PERMITTED FILLED AREAS
-  PROPOSED WASTE AREAS
-  PROPOSED MONITORING WELLS

**HAWTHORN PARK RECLAMATION PROJECT  
AND RECYCLING CENTER  
HARRIS COUNTY, TEXAS**

 **McBride-Ratcliff and Associates, Inc.**  
A Subsidiary of The Badger Company, Inc.

**SANIFILL OF TEXAS, INC.**

SCALE NOTED	DRAWN CHECK	LLD/SMH JRL	DATE 9-15-93 DATE 9-15-93	PROJECT NO. 90-0638
-------------	-------------	----------------	------------------------------	------------------------

HOUSTON, TEXAS

**MONITORING WELL LOCATIONS**

FIGURE  
11-L

III-4H-2

11-31-93

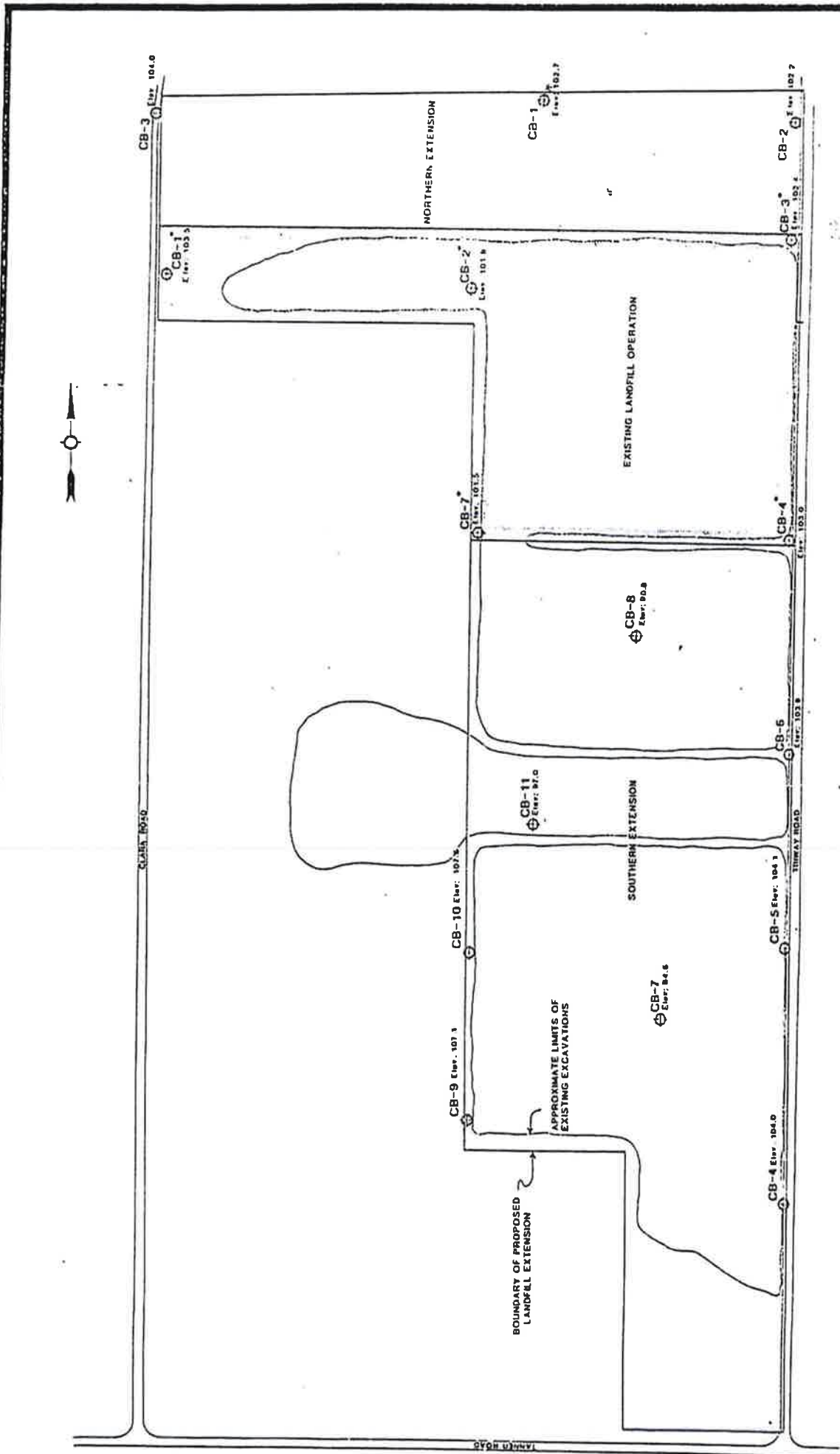

\* BORINGS DRILLED FOR ORIGINAL SOILS REPORT FOR PERMIT APPLICATION NO. 1428

SCALE - FT  
0 100 200 300

**McBride-Ratcliff and Associates, Inc.**  
Consulting Engineers

---

**TYPE IV LANDFILL**  
PERMIT APPLICATION NO. 1440-A  
HARRIS COUNTY, TEXAS

---

**BSI CONSTRUCTION SERVICE, INC.**  
HOUSTON TEXAS

---

PLAN OF BORINGS

DATE: 1-18-87  
DRAWN BY: J. L. S.  
CHECKED BY: J. L. S.  
SCALE: AS SHOWN  
SHEET NO. 1



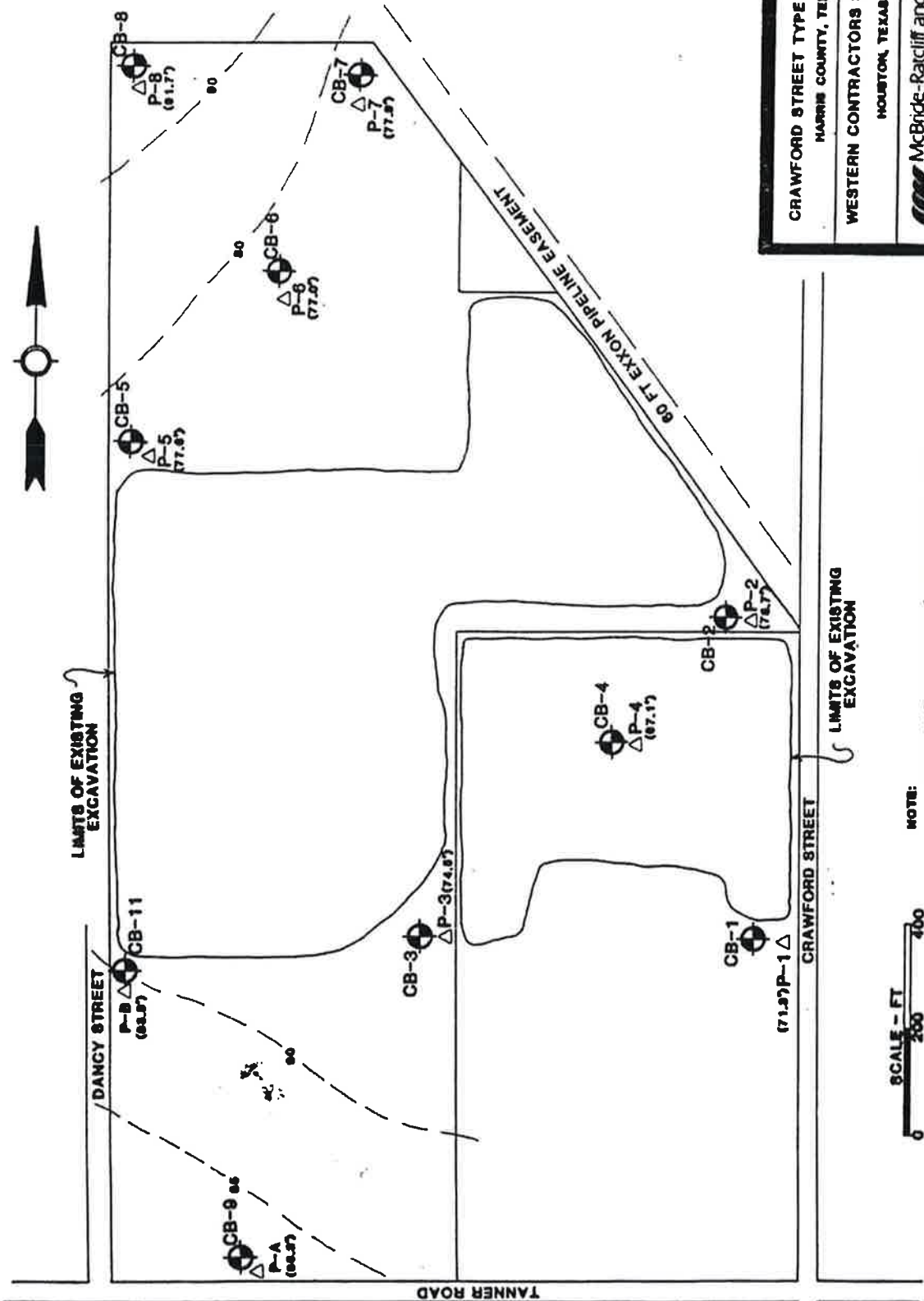

CRAWFORD STREET TYPE IV LANDFILL	
HARRIS COUNTY, TEXAS	
WESTERN CONTRACTORS SERVICES, INC.	
HOUSTON, TEXAS	
SCALE	VERT 1"=20'-00"
NOTED	DATE 2-28-84
	BY 2-28-84
	PI NO 88-1500
	PLAN 8
SHALLOW GROUNDWATER ELEVATIONS	

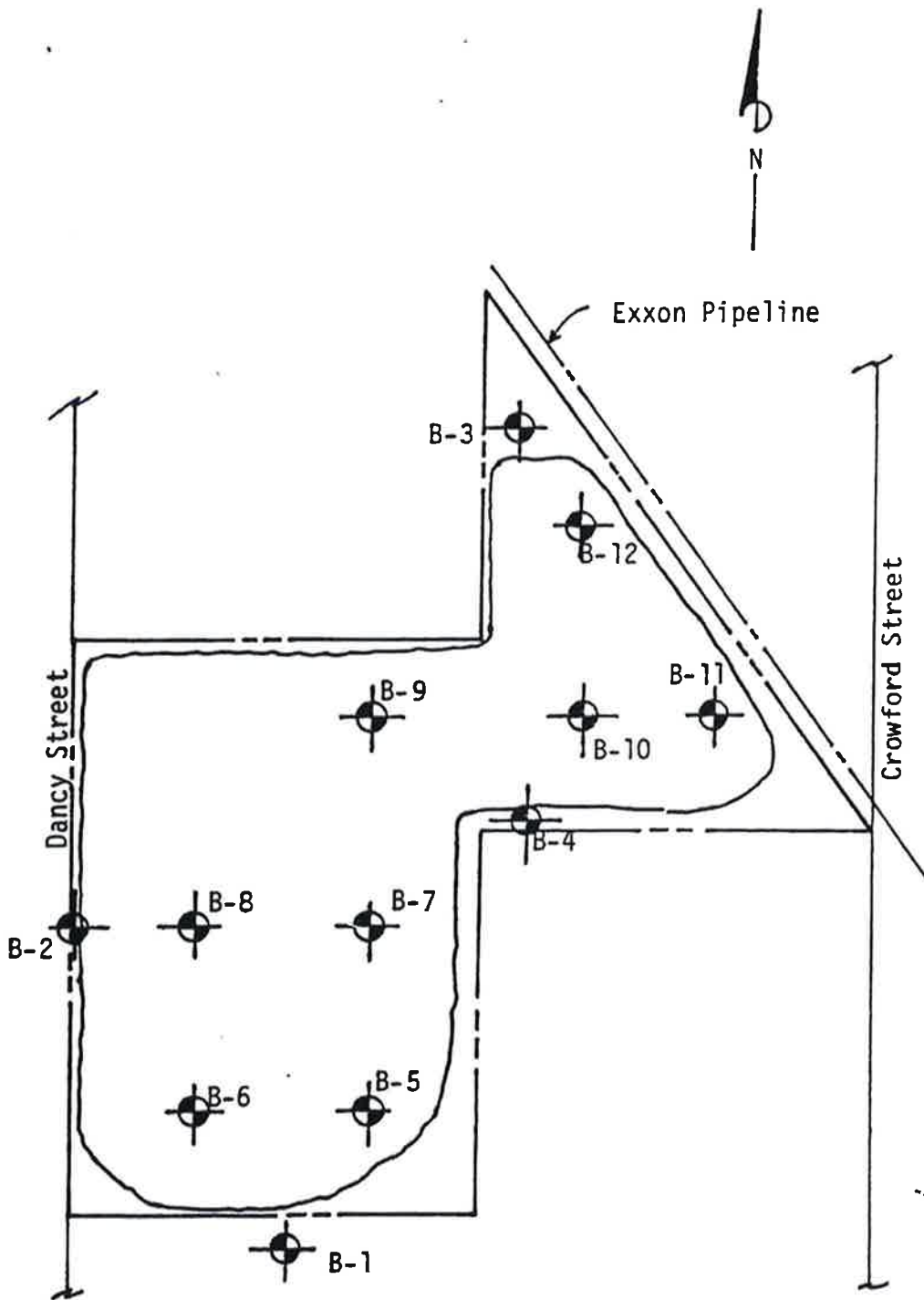

Boring Plan  
November 1982

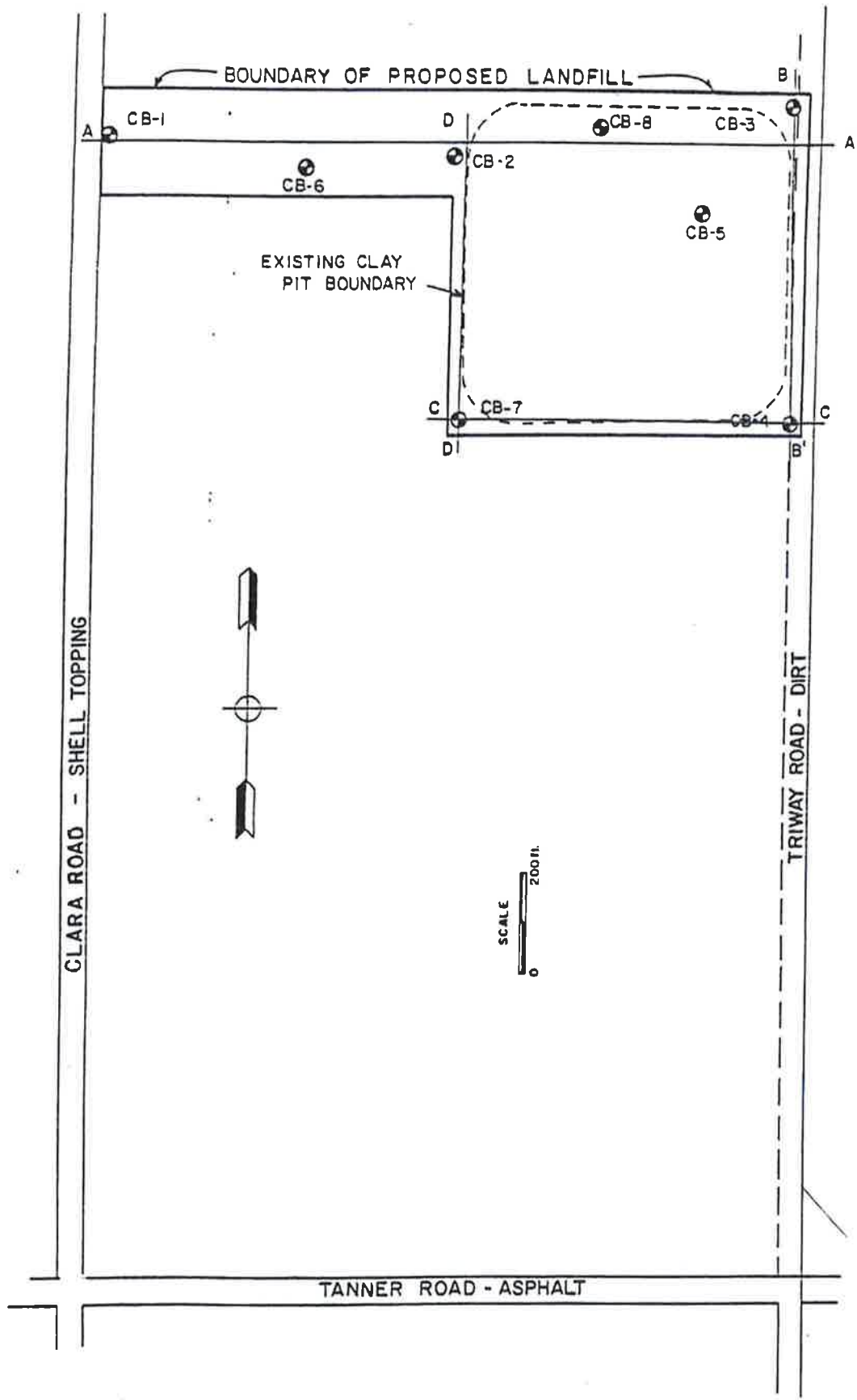

**McBride-Ratcliff and Associates, Inc.**  
 Geotechnical Consultants  
 Houston, Texas

DATE: 2-26-81  
 DRAWN BY: 5-21-81  
 PROJECT NO.: 80-269  
 SHEET NO.: 1

**TYPE IV SANITARY LANDFILL APPLICATION**  
 HOUSTON, TEXAS

**B.S.I. CONSTRUCTION SERVICES, INC.**  
 HOUSTON, TEXAS

PLAN OF BORINGS

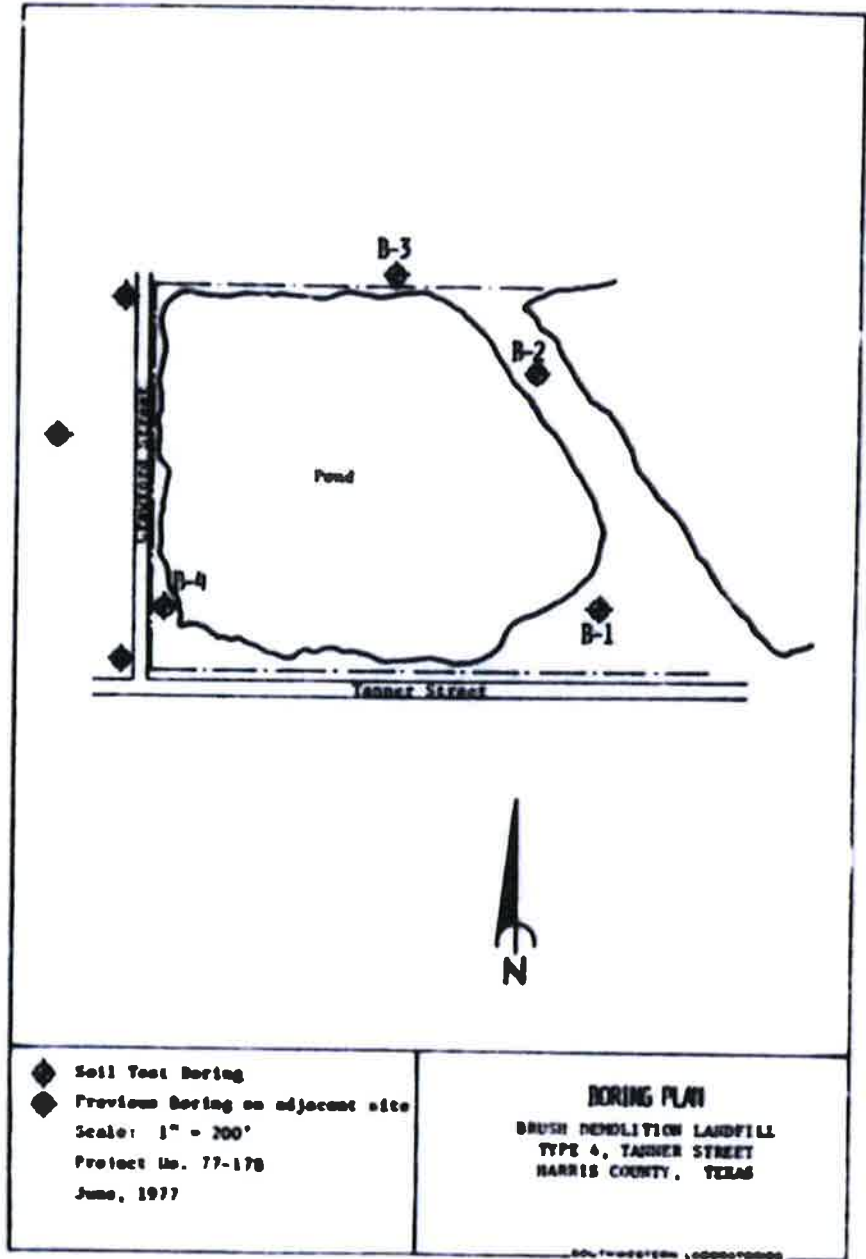

◆ Soil Test Boring  
 ◆ Previous Boring on adjacent site  
 Scale: 1" = 200'  
 Project No. 77-178  
 June, 1977

**BORING PLAN**  
 BRUSH DEMOLITION LANDFILL  
 TYPE 4, TANNER STREET  
 HARRIS COUNTY, TEXAS

SOIL TEST BORING LOGS

A-1

**GEOLOGIC CROSS SECTIONS**



11/17/2008 11:47 AM KORNICA MINOLTA C352\_C300

# CROSS-SECTION A-A'

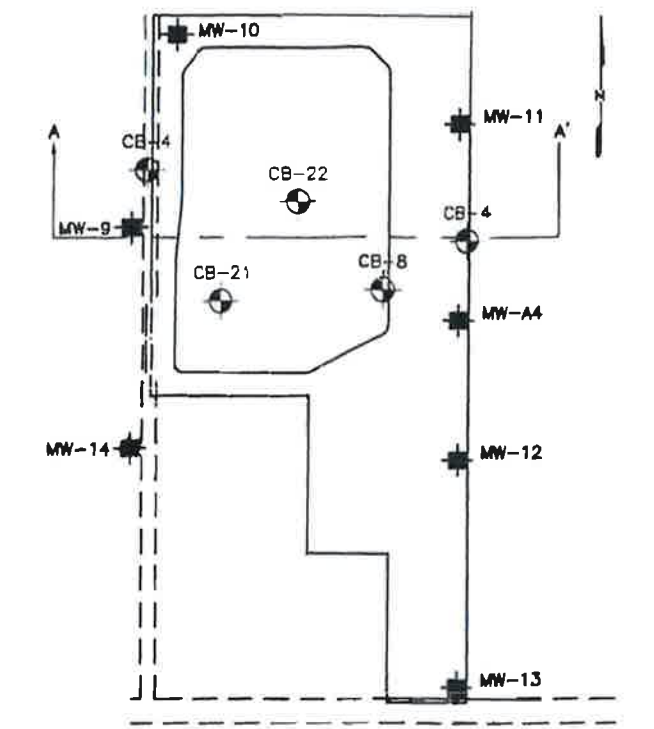
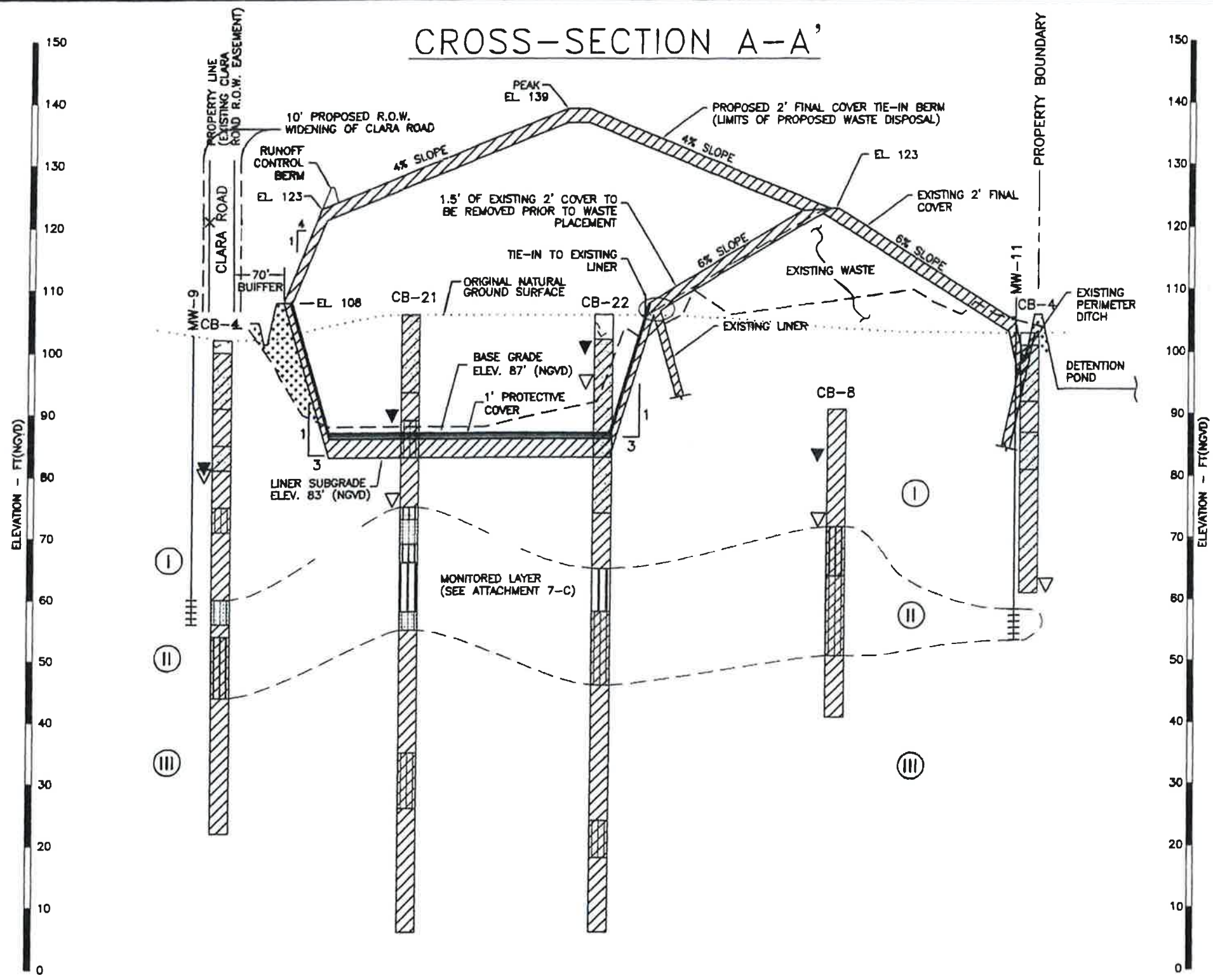

### LEGEND:

- CONSTRUCTED BERM/ACCESS ROAD AND RECONSTRUCTED BUFFER ZONE, WHERE APPLICABLE. (SEE SLQCP FOR DETAILS.)
- OBSERVED STATIC GROUNDWATER LEVEL
- FREE WATER ENCOUNTERED
- CB-21 CORE BORING
- MW-11 PROPOSED MONITORING WELL
- - - - - APPROX. GROUND SURFACE FROM AERIAL FLOWN - AUGUST 1992
- ..... ORIGINAL NATURAL GROUND SURFACE
- ① SOIL LAYER DESIGNATION

### SOIL TYPE

- FILL
- CLAY
- SANDY CLAY
- SILTY CLAY
- SAND
- CLAYEY SAND
- SILTY SAND
- SILT
- CLAYEY SILT
- SANDY SILT

### NOTES:

1. SOIL BORINGS ARE PROJECTED TO CROSS-SECTION. ACTUAL BORING LOCATIONS ARE SHOWN ON INSET MAP AND ATTACHMENT 11-A. ACTUAL BORING LOGS ARE ALSO IN ATTACHMENT 11.
2. SUBSOIL PROFILE INTERPOLATED BETWEEN BORINGS. ACTUAL CONDITIONS MAY VARY FROM THOSE ILLUSTRATED.
3. VERTICAL EXAGGERATION FACTOR = 10
4. NOT FOR CONSTRUCTION. FOR PERMITTING USE ONLY.
5. CROSS-SECTION LOCATION ALSO SHOWN ON ATTACHMENT 6-A1.
6. MONITORING WELL DETAILS ARE SHOWN ON ATTACHMENT 7-C1 AND 7-C2.
7. METHANE PROBES AND VENTS ARE SHOWN ON ATTACHMENT 9-A1, 9-B, AND 9-C.

III-4H-8

REF:  
 BASE MAP FOR THIS DRAWING FROM DRAWING PREPARED BY McBRIDE-RATCLIFF AND ASSOCIATES, INC. SEALED ON 08/26/1993 BY PAUL A. PABOR.



THIS DOCUMENT WAS SEALED ON 6/16/2008 FOR

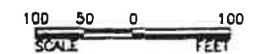

REVISED BY GOLDER ASSOCIATES INC.

Date	Revision/Description
4/06	EAST BLOCK WASTE FOR BALLAST
2/2008	RUNOFF CONTROL BERM
6/2008	GENERAL
Drawn by: <i>art</i>	Checked by: <i>art</i>
Project No. 028109-3	Drawn Date 3/2008

**TYPICAL FILL CROSS-SECTION A-A' FOR EAST BLOCK**

HAWTHORN PARK RECLAMATION PROJECT  
 TCEQ PERMIT NO. MSW 2185  
 USA WASTE OF TEXAS LANDFILLS, INC.

**Metroplex** 14423 Comptonville Village Drive Houston, Texas 77014 Telephone: 281.440.3503 Fax: 281.444.3376

Attachment No. 7



# CROSS-SECTION B-B'

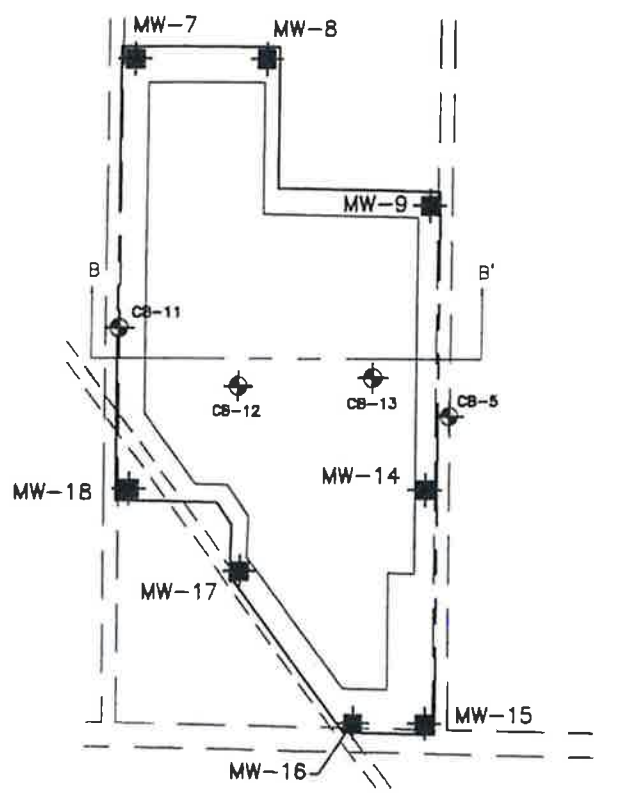
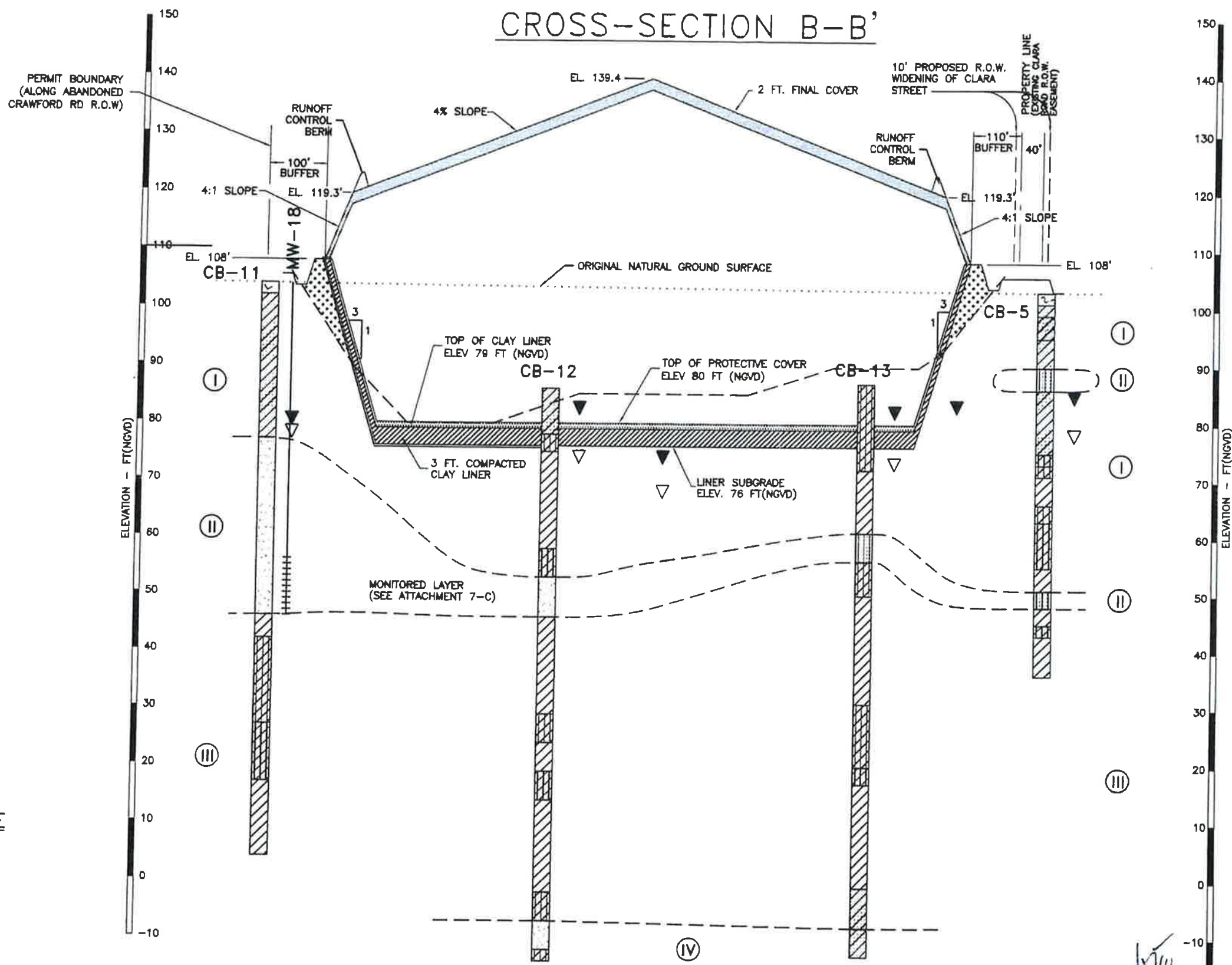

### SOIL TYPE

- FILL
- CLAY
- SANDY CLAY
- SILTY CLAY
- SAND
- CLAYEY SAND
- SILTY SAND
- SILT
- CLAYEY SILT
- SANDY SILT

- NOTES:**
- SOIL BORINGS ARE PROJECTED TO CROSS-SECTION. ACTUAL BORING LOCATIONS ARE SHOWN ON INSERT MAP AND ATTACHMENT 11-A. ACTUAL BORING LOGS ARE ALSO LOCATED IN ATTACHMENT 11.
  - SUBSOIL PROFILE INTERPOLATED BETWEEN BORINGS. ACTUAL CONDITIONS MAY VARY FROM THOSE ILLUSTRATED.
  - VERTICAL EXAGGERATION = 10
  - NOT FOR CONSTRUCTION. FOR PERMITTING USE ONLY.
  - CROSS-SECTION LOCATION ALSO SHOWN ON ATTACHMENT 6-A2.
  - MONITORING WELL DETAILS ARE SHOWN ON ATTACHMENT 7-C1 AND 7-C2.
  - METHANE PROBES AND VENTS ARE SHOWN ON ATTACHMENT 9-A2, 9-B, AND 9-C.

- LEGEND:**
- CONSTRUCTED BERM/ACCESS ROAD AND RECONSTRUCTED BUFFER ZONE, WHERE APPLICABLE. (SEE SLQCP FOR DETAILS.)
  - OBSERVED STATIC GROUNDWATER LEVEL
  - FREE WATER ENCOUNTERED
  - CB-21** CORE BORING
  - MW-18** PROPOSED MONITORING WELL LOCATION
  - APPROX. GROUND SURFACE FROM AERIAL FLOWN - JULY 1990
  - ORIGINAL NATURAL GROUND SURFACE
  - SOIL LAYER DESIGNATION

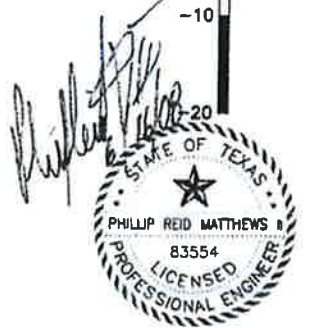

REF: BASE MAP FOR THIS DRAWING FROM DRAWING PREPARED BY MCBRIDE-RATCLIFF AND ASSOCIATES, INC. SEALED ON 08/26/1993 BY PAUL A. PAROR

III-4H-9

THIS DOCUMENT WAS SEALED ON 6/16/2008 FOR REBIDDING BY 2008FC-ANXK

TYPICAL FILL  
CROSS-SECTION B-B'  
FOR CENTER BLOCK

REVISED BY GOLDER ASSOCIATES INC.	
Date	Revision/Description
4/2008	GENERAL
6/2008	GENERAL
Drawn By	Checked By
JMT	PMW
Project No.	Dep. Date
022109-3	2/2008

**HAWTHORN PARK RECLAMATION PROJECT**  
TCEQ PERMIT NO. MSW 2185  
USA WASTE OF TEXAS LANDFILLS, INC.

14423 Cornerstone Village Drive  
Houston, Texas 77014  
Telephone: 281.440.5503  
Facsimile: 281.444.3376

Attachment No. 7-A2.1

C:\Users\mroberts\OneDrive\Documents\2008\2008-07-27\0008-07-27-A2.DWG, 6/17/2008 8:42:12 AM, KONICA MINOLTA C352.C3



# CROSS-SECTION C-C'

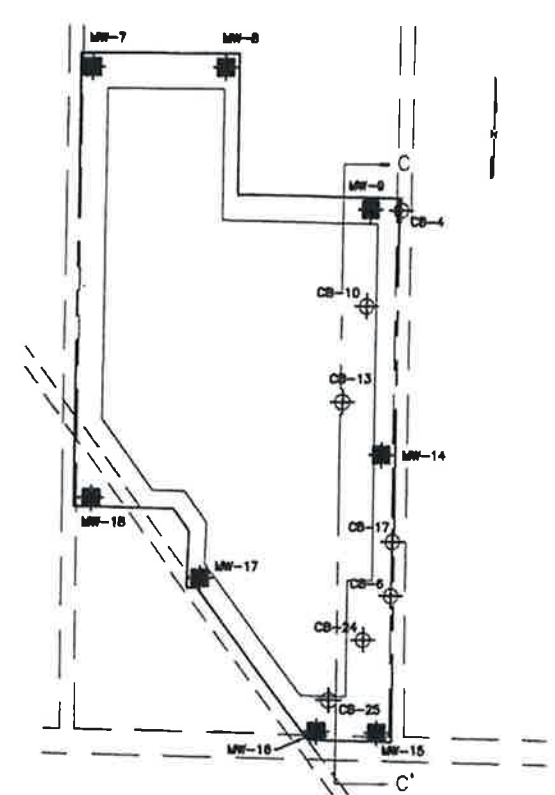
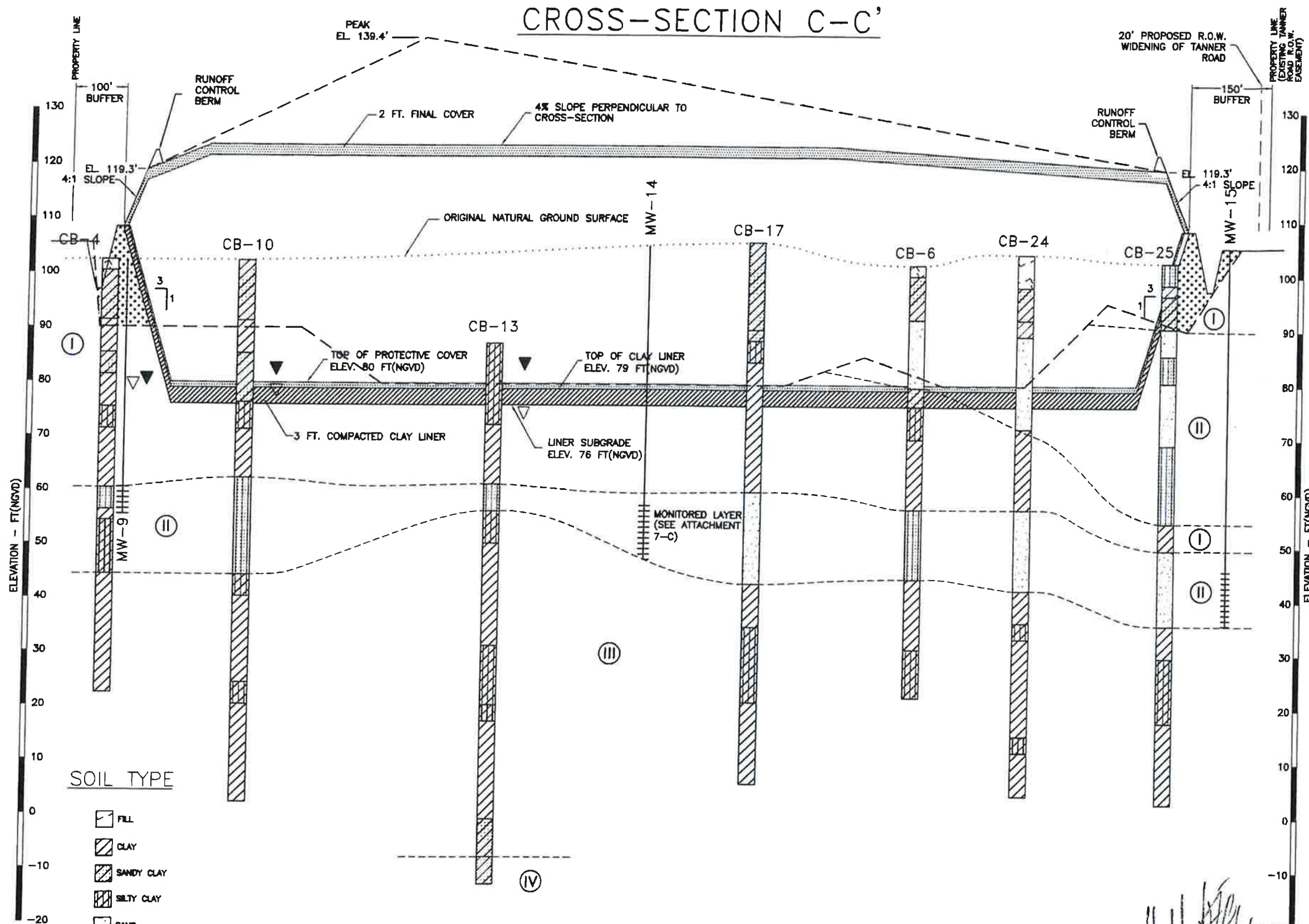

- LEGEND:**
- CONSTRUCTED BERM/ACCESS ROAD AND RECONSTRUCTED BUFFER ZONE, WHERE APPLICABLE. (SEE SLQCP FOR DETAILS.)
  - OBSERVED STATIC GROUNDWATER LEVEL
  - FREE WATER ENCOUNTERED
  - CB-24 CORE BORING
  - APPROX. GROUND SURFACE FROM AERIAL FLOWN - JULY 1990
  - SOIL LAYER DESIGNATION
  - ORIGINAL NATURAL GROUND SURFACE
  - MW-14 PROPOSED MONITORING WELL

**SOIL TYPE**

- FILL
- CLAY
- SANDY CLAY
- SILTY CLAY
- SAND
- CLAYEY SAND
- SILTY SAND
- SILT
- CLAYEY SILT
- SANDY SILT

**NOTES:**

1. SOIL BORINGS ARE PROJECTED TO CROSS-SECTION. ACTUAL BORING LOCATIONS ARE SHOWN ON ATTACHMENT 11-A.
2. SUBSOIL PROFILE INTERPOLATED BETWEEN BORINGS. ACTUAL CONDITIONS MAY VARY FROM THOSE ILLUSTRATED.
3. VERTICAL EXAGGERATION = 10
4. NOT FOR CONSTRUCTION. FOR PERMITTING USE ONLY.

REF: BASE MAP FOR THIS DRAWING FROM DRAWING PREPARED BY MCBRIDE-RATCLIFF AND ASSOCIATES, INC. SEALED ON 08/26/1993 BY PAUL A. PABOR.

III-4H-10

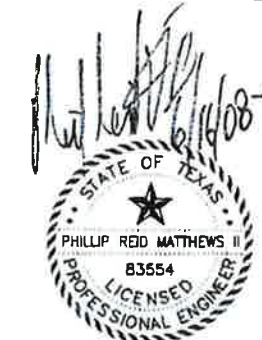

THIS DOCUMENT WAS SEALED ON 6/16/2008 FOR



REVISED BY GOLDER ASSOCIATES INC.

Date	Revision/Description
12/07	GENERAL
8/2008	GENERAL

HAWTHORN PARK RECLAMATION PROJECT  
TCEQ PERMIT NO. MSW 2185  
USA WASTE OF TEXAS LANDFILLS, INC.

**Metroplex** 14423 Cornerstone Village Drive Houston, Texas 77014 Telephone: 281-440-5303 Fax: 281-444-3374 Attachment No.

2008 06 16 11:17:11 AM KONICA MINOLTA C552\_C30F -3, 11, 17, 1, 200

# CROSS-SECTION D-D'

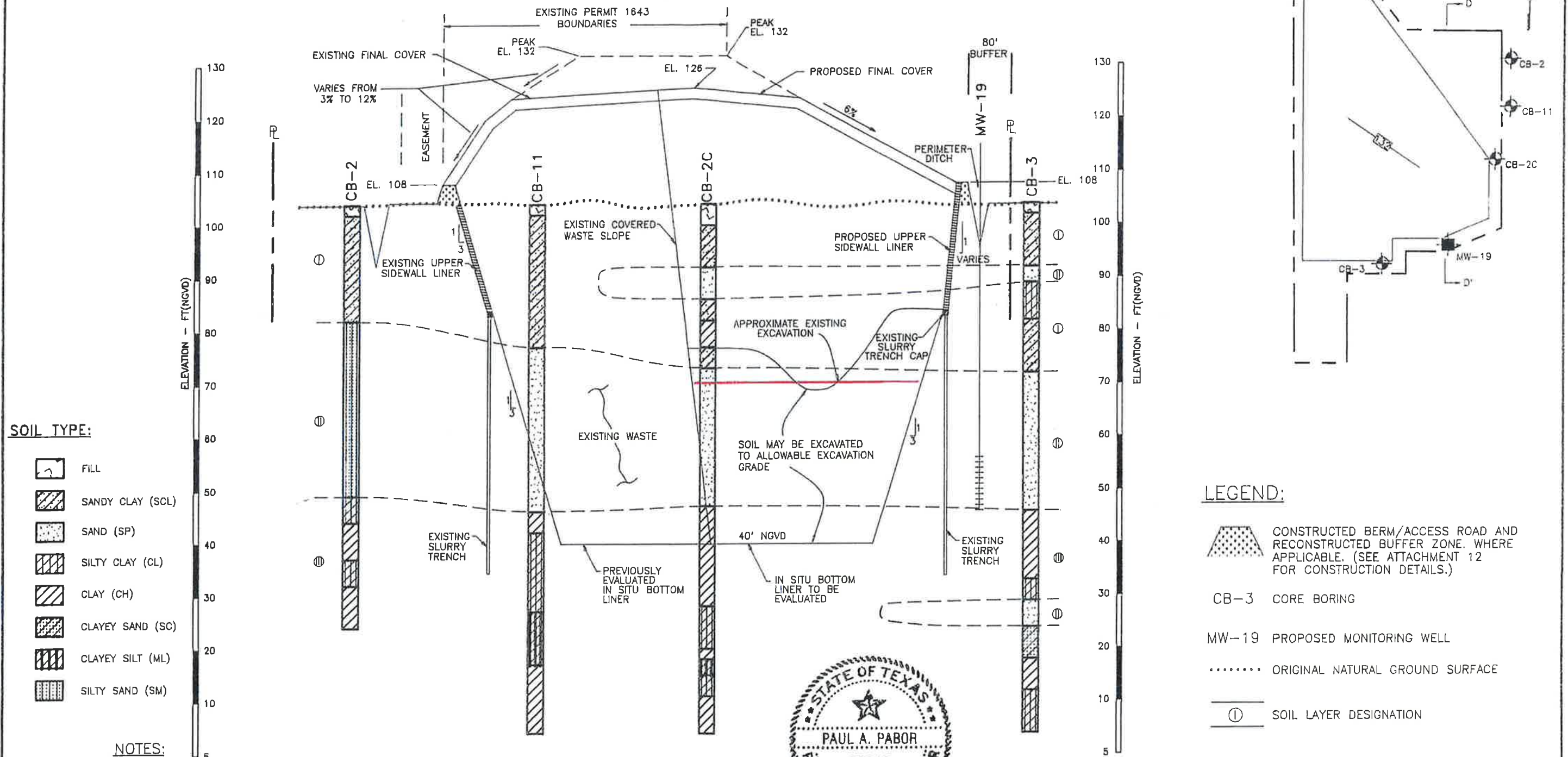

### SOIL TYPE:

- FILL
- SANDY CLAY (SCL)
- SAND (SP)
- SILTY CLAY (CL)
- CLAY (CH)
- CLAYEY SAND (SC)
- CLAYEY SILT (ML)
- SILTY SAND (SM)

### NOTES:

1. SOIL BORINGS ARE PROJECTED TO CROSS-SECTION. ACTUAL BORING LOCATIONS ARE SHOWN ON INSET MAP AND ATTACHMENT 11-A. ACTUAL BORING LOGS ARE ALSO IN ATTACHMENT 11.
2. SUBSOIL PROFILE INTERPOLATED BETWEEN BORINGS. ACTUAL CONDITIONS MAY VARY FROM THOSE ILLUSTRATED.
3. VERTICAL EXAGGERATION FACTOR = 10
4. NOT FOR CONSTRUCTION. FOR PERMITTING USE ONLY.
5. CROSS-SECTION LOCATION ALSO SHOWN ON ATTACHMENT 6-A3.
6. MONITORING WELL DETAILS ARE SHOWN ON ATTACHMENT 7-C1 AND 7-C2.
7. METHANE PROBES AND VENTS ARE SHOWN ON ATTACHMENT 9-A3, 9-B, AND 9-C.

### LEGEND:

- CONSTRUCTED BERM/ACCESS ROAD AND RECONSTRUCTED BUFFER ZONE. WHERE APPLICABLE. (SEE ATTACHMENT 12 FOR CONSTRUCTION DETAILS.)
- CB-3 CORE BORING
- MW-19 PROPOSED MONITORING WELL
- ..... ORIGINAL NATURAL GROUND SURFACE
- ① SOIL LAYER DESIGNATION



HAWTHORN PARK RECLAMATION PROJECT  
AND RECYCLING CENTER

HARRIS COUNTY, TEXAS

SANIFILL OF TEXAS, INC.

HOUSTON, TEXAS

**McBride-Ratcliff and Associates, Inc.**  
A Subsidiary of The Badger Company, Inc.

SCALE NOTED	DRAWN CHECK	JRR TWJ/PAP	DATE DATE	11-9-93 11-9-93	PROJECT NO. 90-0638
TYPICAL FILL CROSS-SECTION D-D' FOR WEST BLOCK					FIGURE 7-A3

REF. NO. 9000-41, 0050



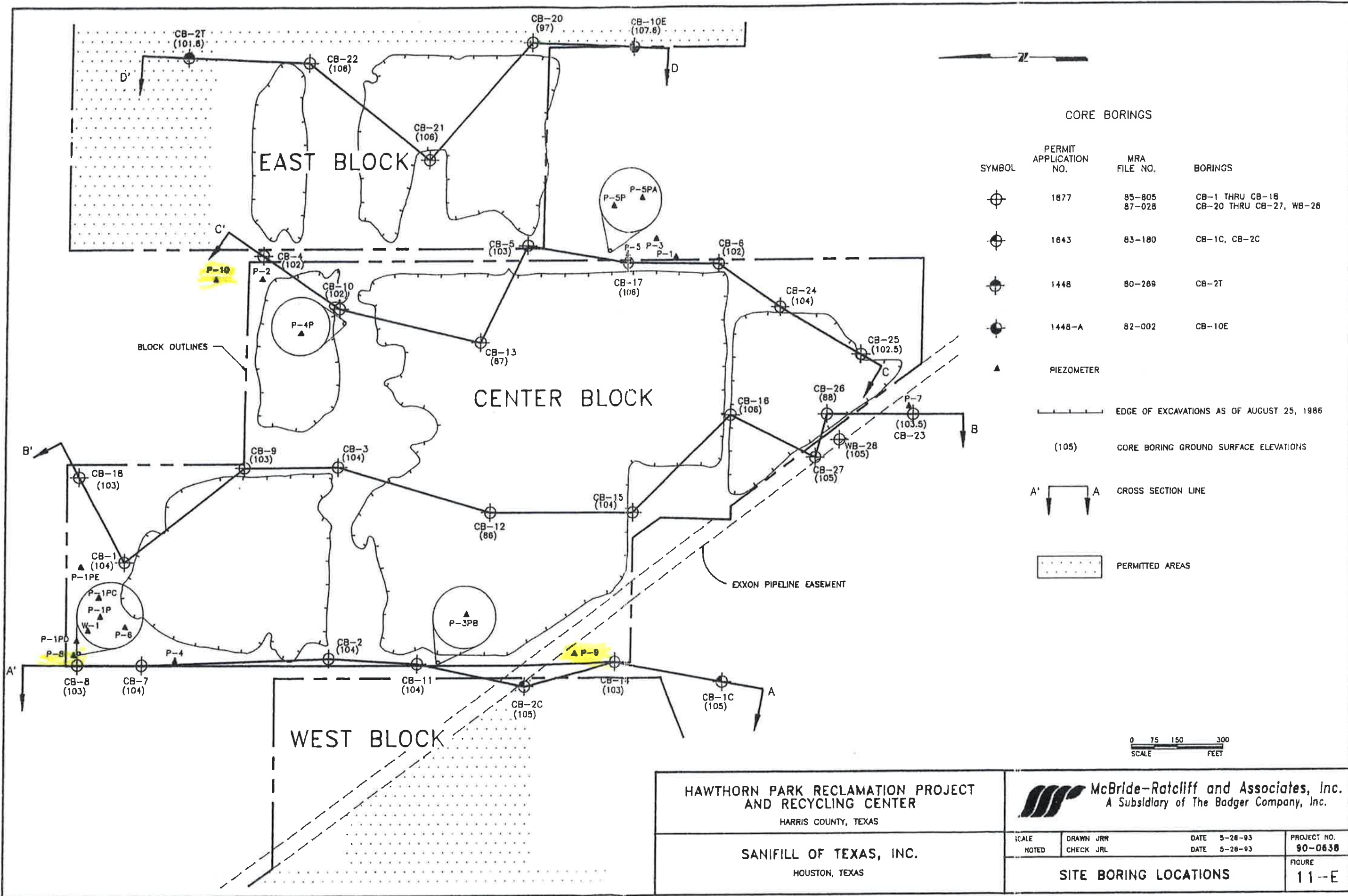

CORE BORINGS

SYMBOL	PERMIT APPLICATION NO.	MRA FILE NO.	BORINGS
⊕	1877	85-805 87-028	CB-1 THRU CB-18 CB-20 THRU CB-27, WB-28
⊕	1643	83-180	CB-1C, CB-2C
⊕	1448	80-269	CB-2T
⊕	1448-A	82-002	CB-10E
▲			PIEZOMETER

- EDGE OF EXCAVATIONS AS OF AUGUST 25, 1986
- (105) CORE BORING GROUND SURFACE ELEVATIONS
- A'—A CROSS SECTION LINE
- ▭ PERMITTED AREAS

HAWTHORN PARK RECLAMATION PROJECT  
AND RECYCLING CENTER  
HARRIS COUNTY, TEXAS

SANIFILL OF TEXAS, INC.  
HOUSTON, TEXAS

**McBride-Ratcliff and Associates, Inc.**  
A Subsidiary of The Badger Company, Inc.

SCALE NOTED	DRAWN JRR CHECK JRL	DATE 5-28-93 DATE 5-28-93	PROJECT NO. <b>90-0638</b>
SITE BORING LOCATIONS			FIGURE <b>11-E</b>

# SECTION A-A'

**SOUTH**

**NORTH**

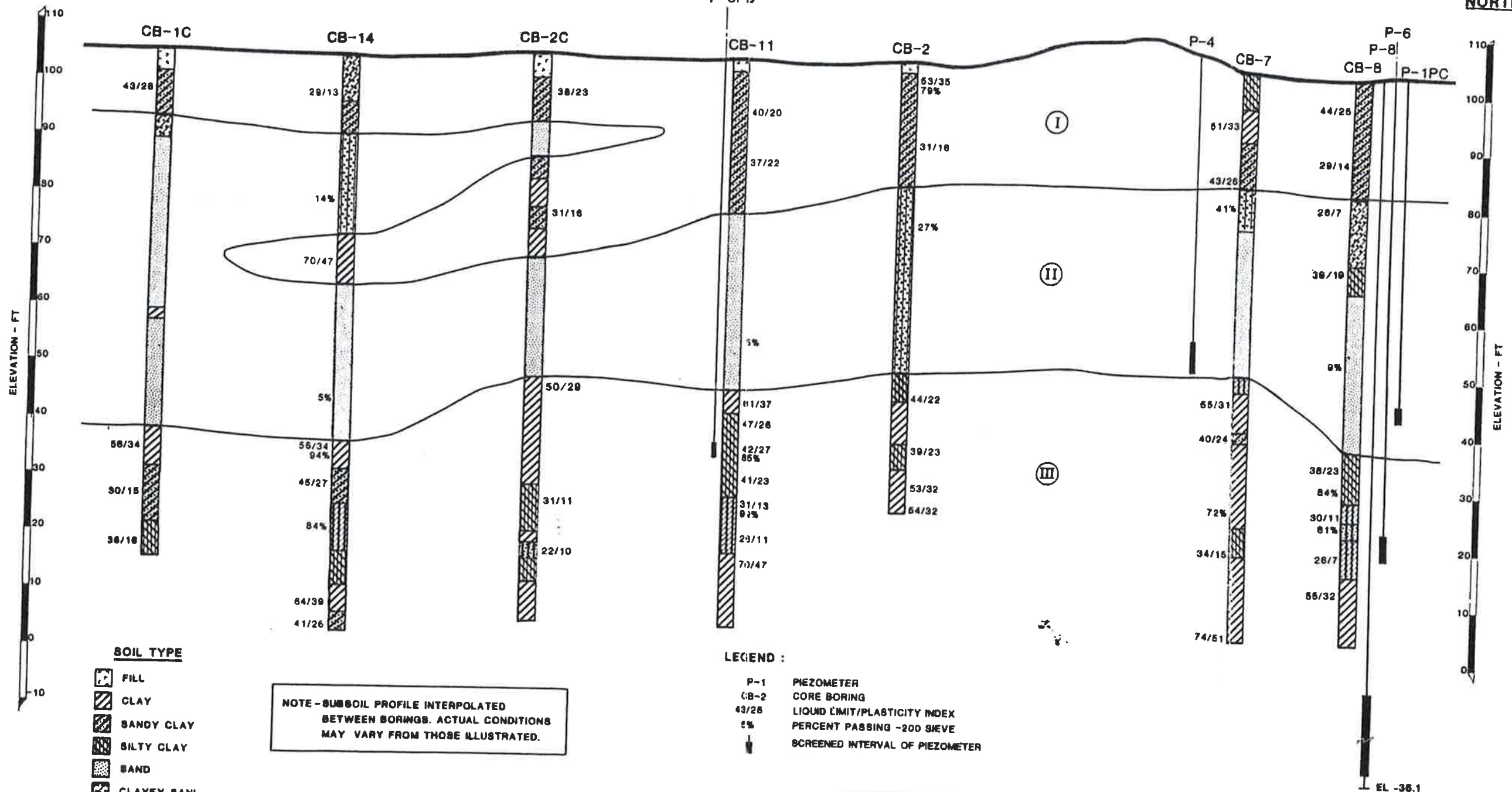

HAWTHORN PARK RECLAMATION PROJECT  
AND RECYCLING CENTER  
HARRIS COUNTY, TEXAS

**McBride-Ratcliff and Associates, Inc.**  
A Subsidiary of The Badger Company, Inc.

**SANIFILL OF TEXAS, INC.**  
HOUSTON, TEXAS

SCALE NOTED	MADE BY JRL	KD/LLD	DATE 5-4-93	REV 5-4-93	PLS NO 90-0638
-------------	-------------	--------	-------------	------------	----------------

**SOIL PROFILE A-A'**  
11-F



# SECTION B-B'

SOUTH

NORTH

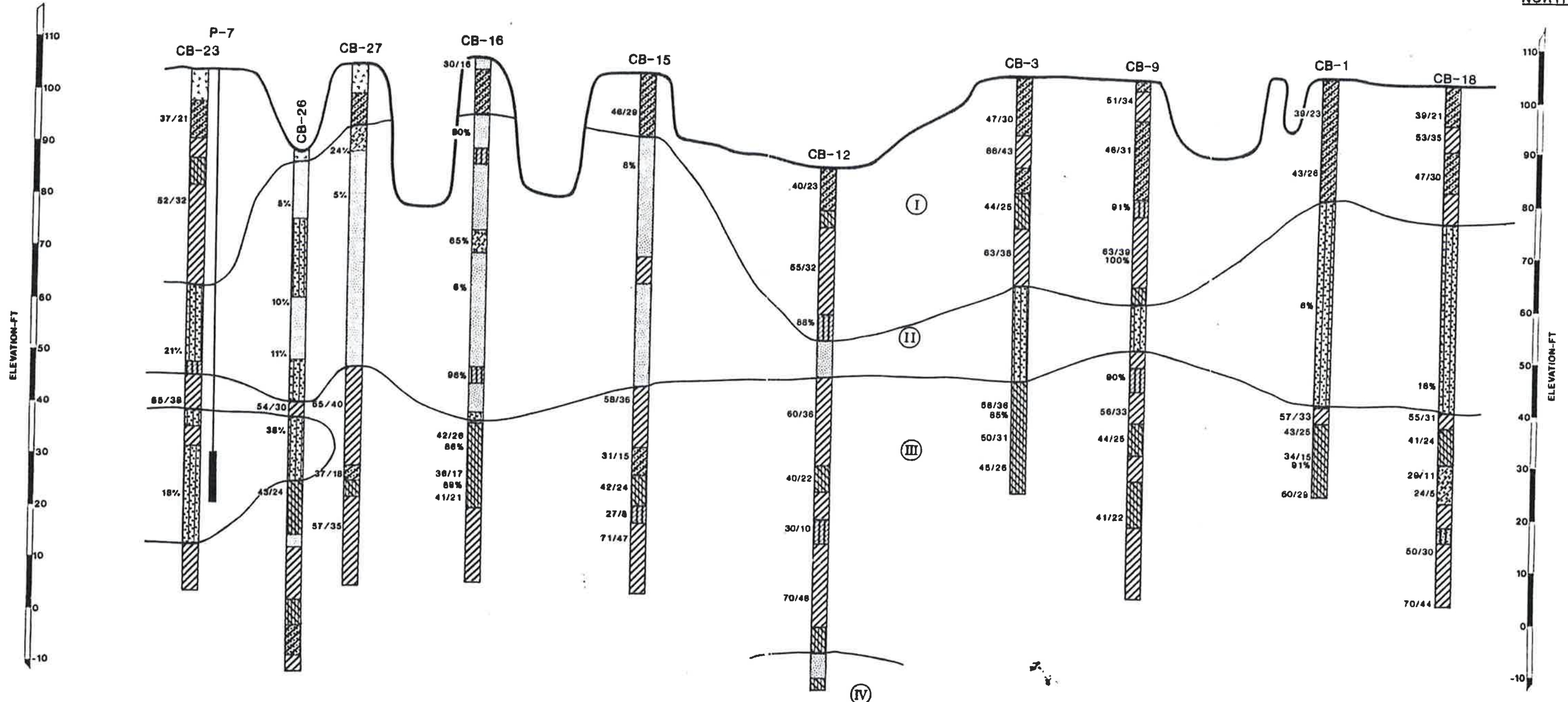

NOTE - SUBSOIL PROFILE INTERPOLATED BETWEEN BORINGS. ACTUAL CONDITIONS MAY VARY FROM THOSE ILLUSTRATED.

- SOIL TYPE**
- FILL
  - CLAY
  - SANDY CLAY
  - SILTY CLAY
  - SAND
  - CLAYEY SAND
  - SILTY SAND
  - SILT
  - CLAYEY SILT
  - SANDY SILT

**LEGEND :**  
 CB-21 CORE BORING  
 43/28 LIQUID LIMIT/PLASTICITY INDEX  
 5% PERCENT PASSING -200 SIEVE  
 SCREENED INTERVAL OF PIEZOMETER

HAWTHORN PARK RECLAMATION PROJECT  
 AND RECYCLING CENTER  
 HARRIS COUNTY, TEXAS

---

SANIFILL OF TEXAS, INC.  
 HOUSTON, TEXAS

**McBride-Ratcliff and Associates, Inc.**  
 A Subsidiary of The Badger Company, Inc.

SCALE NOTED	PAGE CHECK	KD/LLD JRL	DATE 5-4-93	DATE 5-4-93	FILE NO 90-0638
SOIL PROFILE B-B'					PLUM 11-G

SECTION C-C

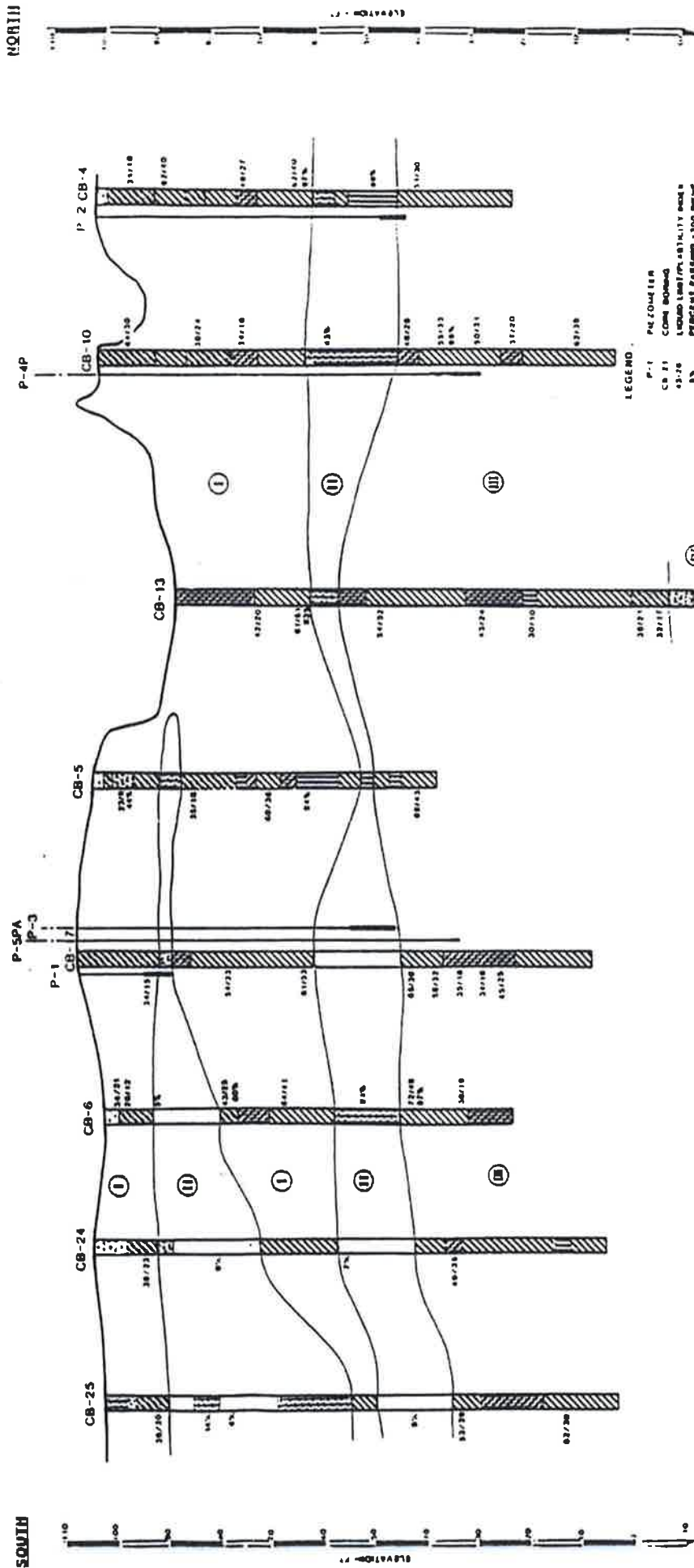

NOTE - SURFACE PROFILE INTERPOLATED BETWEEN BORINGS. ACTUAL CONDITIONS MAY VARY FROM THOSE ILLUSTRATED.



**HAWTHORN PARK RECLAMATION PROJECT AND RECYCLING CENTER**  
HARRIS COUNTY, TEXAS

**SANIFILL OF TEXAS, INC.**  
HOUSTON, TEXAS

**McBride-Raciff and Associates, Inc.**  
A Subsidiary of The Bodeger Company, Inc.

DATE	PROJECT NO.	SCALE	SHEET NO.	TOTAL SHEETS
10/10/10	100	1" = 40'	3	3

11-11

SECTION D-D

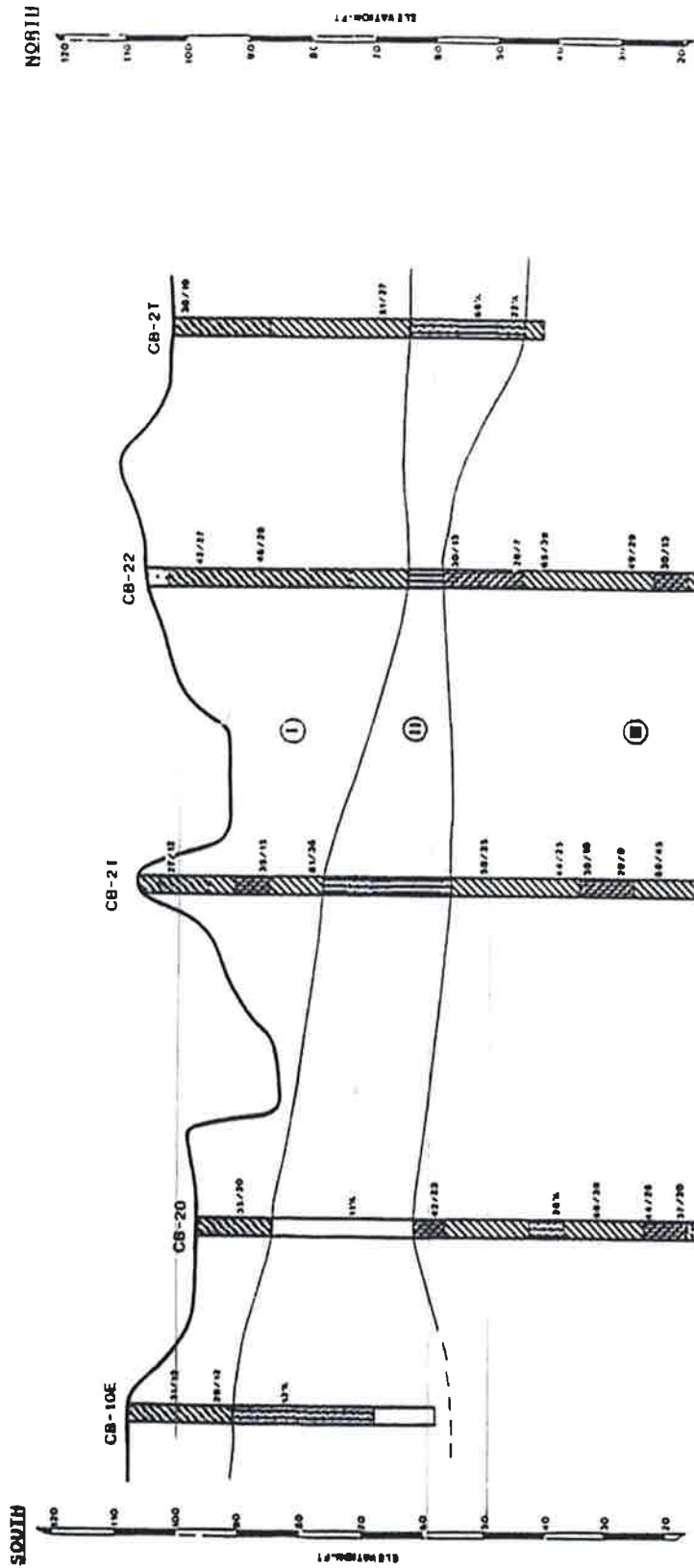

III-4H-16

**McBride-Rachiff and Associates, Inc.**  
 A Subsidiary of The Geogri Corporation, Inc.

**MAWTHORN PARK RECLAMATION PROJECT AND RECYCLING CENTER**  
 HARRIS COUNTY, TEXAS

**SANIFILL OF TEXAS, INC.**

DATE	NO. OF	DATE	NO. OF
NOTED	CHG.	REV.	BY
		5-4-83	MLM
		5-8-83	MLM
		8-11-83	MLM

SCALE 1" = 20'



SOIL LAYER      SOIL DESCRIPTION AND CLASSIFICATION

- I  Medium-Hard CLAY (CH) SANDY CLAY (CL) & SILTY CLAY (CL)
- II  Firm-Very Dense FINE SAND (SP), SILTY FINE SAND (SM), CLAYEY SAND (SC) SANDY SILT (ML) & CLAYEY SILT (ML)
- III  Stiff-Hard CLAY (CH) SANDY CLAY (CL) & SILTY CLAY (CL)
- IV  FINE SAND (SP) & SILTY FINE SAND (SM)
-  PROPOSED WASTE AREAS

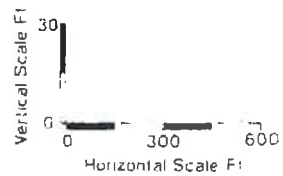

**HAWTHORN PARK RECLAMATION PROJECT  
AND RECYCLING CENTER**  
HARRIS COUNTY, TEXAS

**SANIFILL OF TEXAS, INC.**  
HOUSTON, TEXAS



**McBride-Ratcliff and Associates, Inc.**  
A Subsidiary of The Badger Company, Inc

SCALE NOTED	MADE SMH/LLD CHECK JRL	DATE 9-13-93 DATE 9-13-93	FILE NO. 9D-0638
-------------	---------------------------	------------------------------	---------------------

**FENCE DIAGRAM**

FIGURE  
**11-D**

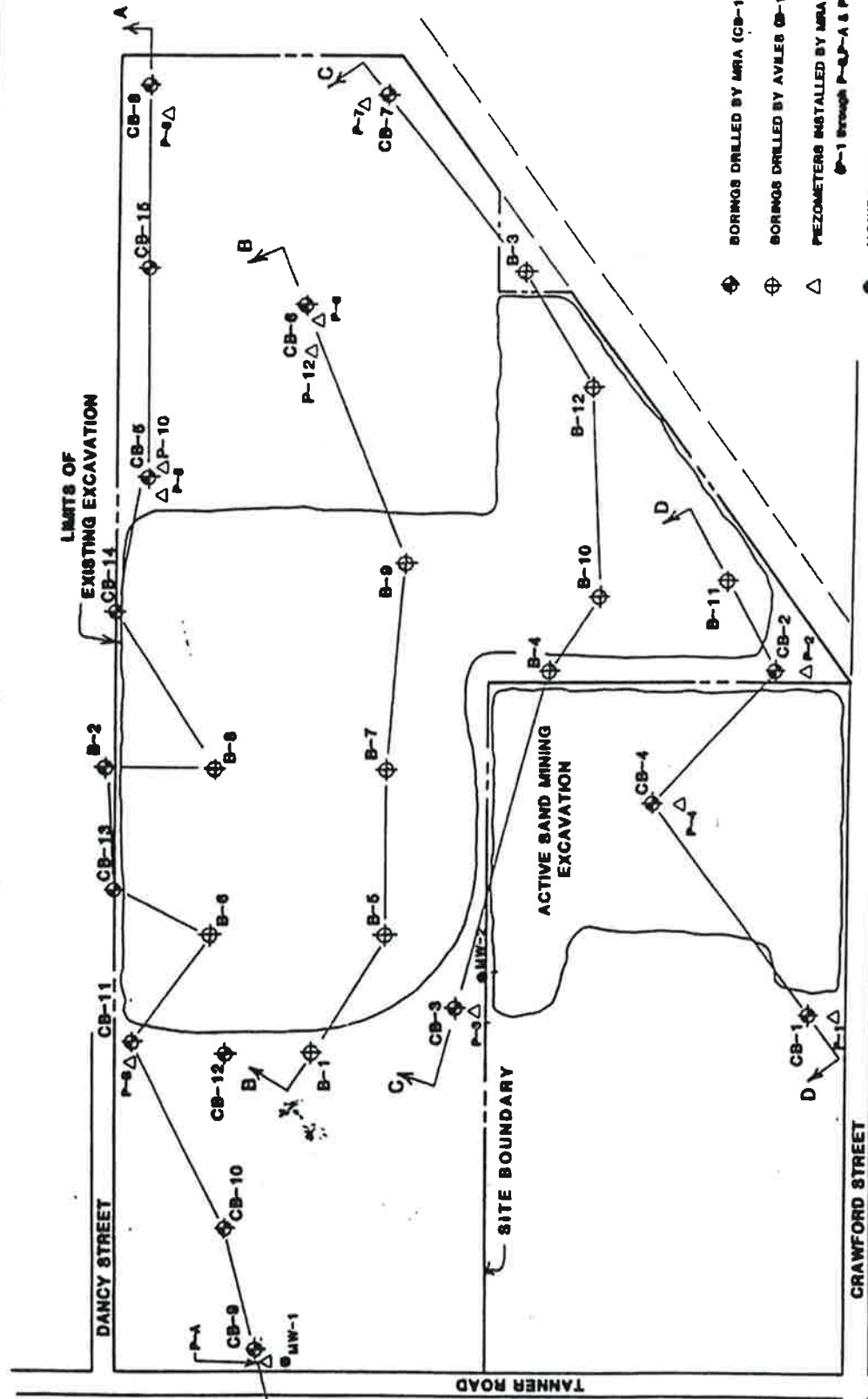

- ◆ BORINGS DRILLED BY MRA (CB-1 through CB-18)
- ⊕ BORINGS DRILLED BY AVILES (B-1 through B-12)
- △ PIEZOMETERS INSTALLED BY MRA (P-1 through P-10)
- MONITORING WELL

**McBride-Ratcliff and Associates, Inc.**  
Geotechnical Consultants  
Houston, Texas

SCALE	DATE	FILE NO.
NOTED	2-18-84	83-180
CHECK	2-18-84	
NAME		
NO.		

**PLAN OF BORINGS**  
PAGE 1

**CRAWFORD STREET TYPE IV LANDFILL**  
HARRIS COUNTY, TEXAS

**WESTERN CONTRACTORS SERVICES, INC.**  
HOUSTON, TEXAS



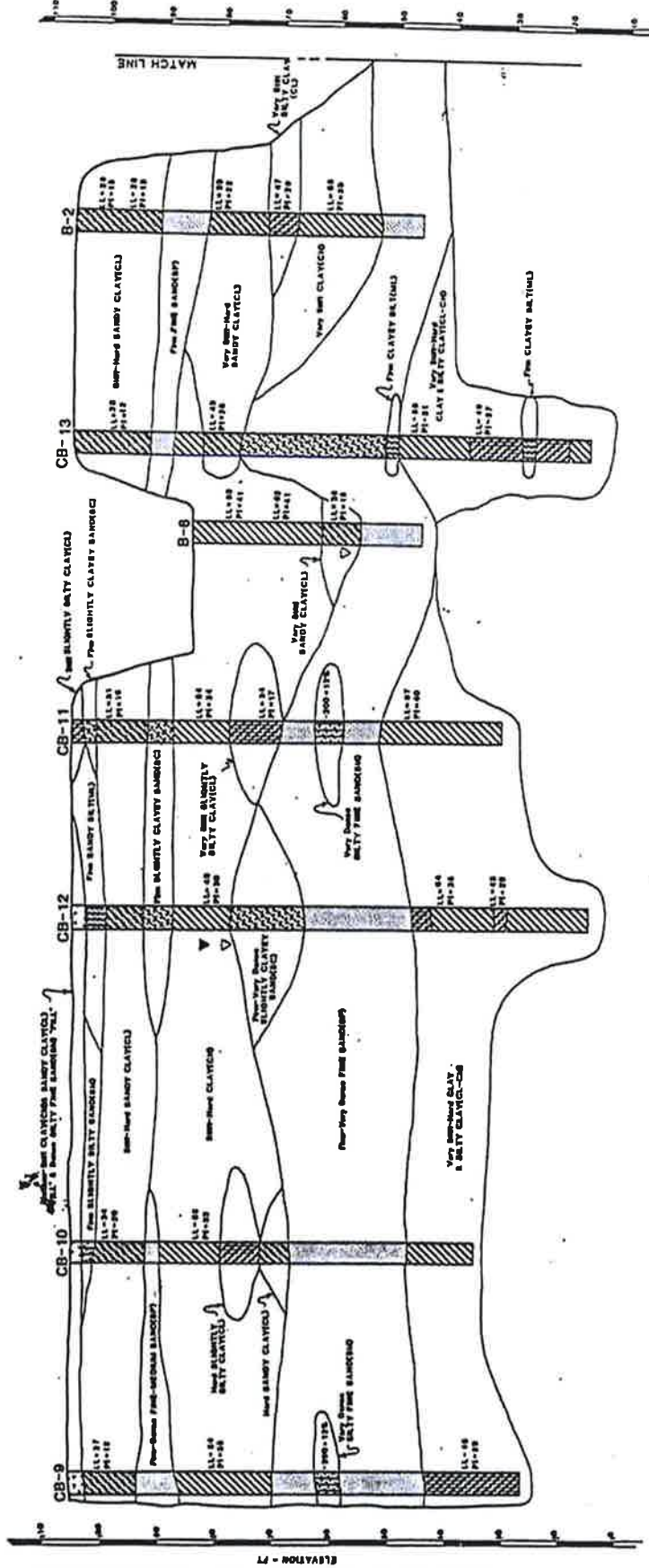

SECTION A-A

NOTE - BORING PROFILE INTERPOLATED BETWEEN BORINGS. ACTUAL CONDITIONS MAY VARY FROM THOSE ILLUSTRATED.



- ▽ OBSERVED STATIC GROUNDWATER LEVEL
- △ FREE WATER ENCOUNTERED

CRAWFORD STREET TYPE IV LANDFILL  
 HARRIS COUNTY, TEXAS  
 WESTERN CONTRACTORS SERVICES, INC.  
 HOUSTON, TEXAS

**McBride-Ratcliff and Associates, Inc.**  
 Geotechnical Consultants  
 Houston, Texas

DATE NOTED: 12-18-81  
 DATE REVISED: 12-18-81  
 DRAWN BY: [Name]  
 CHECKED BY: [Name]



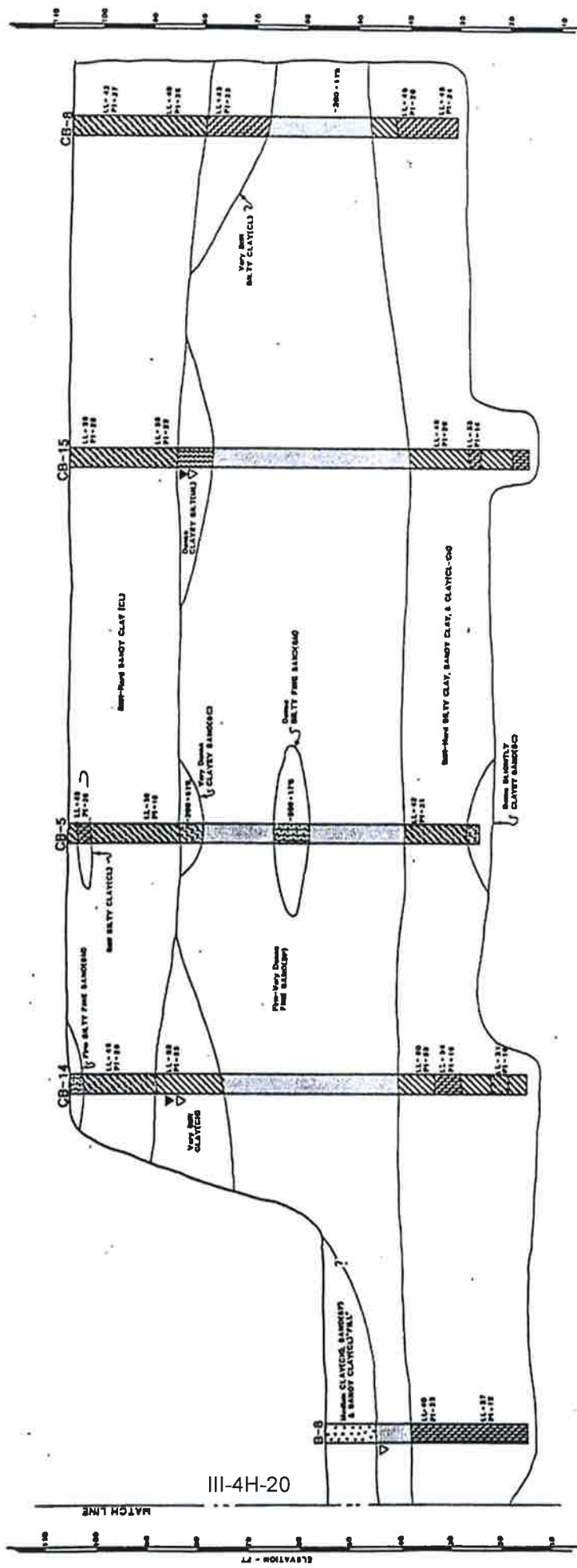

SECTION A-A

NOTE - SUBSOIL PROFILE INTERPOLATED BETWEEN BORINGS - ACTUAL CONDITIONS MAY VARY FROM THOSE ILLUSTRATED.



▽ OBSERVED STATIC GROUNDWATER LEVEL  
▽ FREE WATER ENCOUNTERED

CRAWFORD STREET TYPE IV LANDFILL  
HARRIS COUNTY, TEXAS

WESTERN CONTRACTORS SERVICES, INC.  
HOUSTON, TEXAS

McBride-Ratliff and Associates, Inc.  
Geotechnical Consultants  
Houston, Texas

DATE	NOV 10 1984	PROJECT	11-10-84
DRAWN BY	CHP/ALP	CHECKED BY	11-10-84
SHEET NO.		2A	

SOIL PROFILE

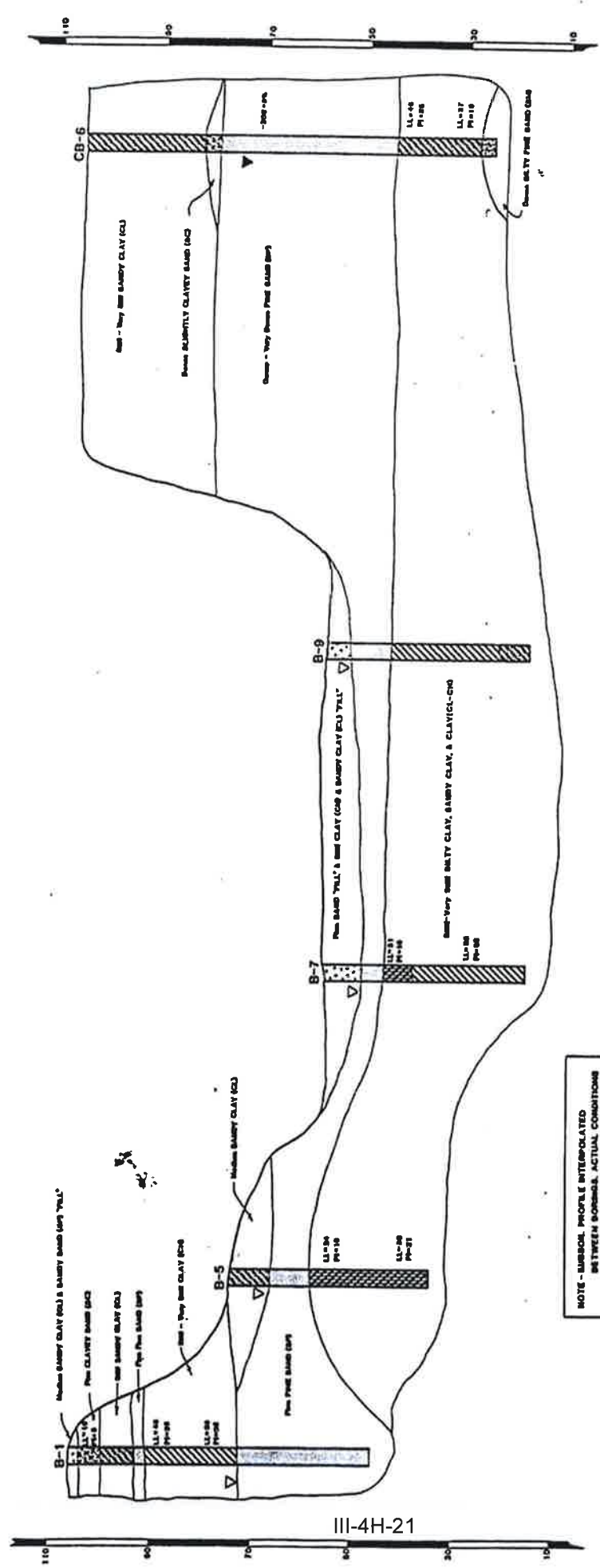

III-4H-21

SCALE-FT.  
0 100 200 300

BORINGS  
CB-1 DRILLED BY MRA  
B-1 DRILLED BY AVLES

### SECTION B-B

NOTE - BORING PROFILE INTERPOLATED  
BETWEEN BORINGS. ACTUAL CONDITIONS  
MAY VARY FROM THOSE ILLUSTRATED.

▽ OBSERVED STATIC GROUNDWATER LEVEL  
△ FREE WATER ENCOUNTERED

		DATE NOTED DATE OF FIELD WORK DATE OF REPORT	DRAWN BY CHECKED BY DATE	PROJECT NO. SHEET NO.
CRAWFORD STREET TYPE IV LANDFILL HARRIS COUNTY, TEXAS		WESTERN CONTRACTORS SERVICES, INC. HOUSTON, TEXAS		SOIL PROFILE 3

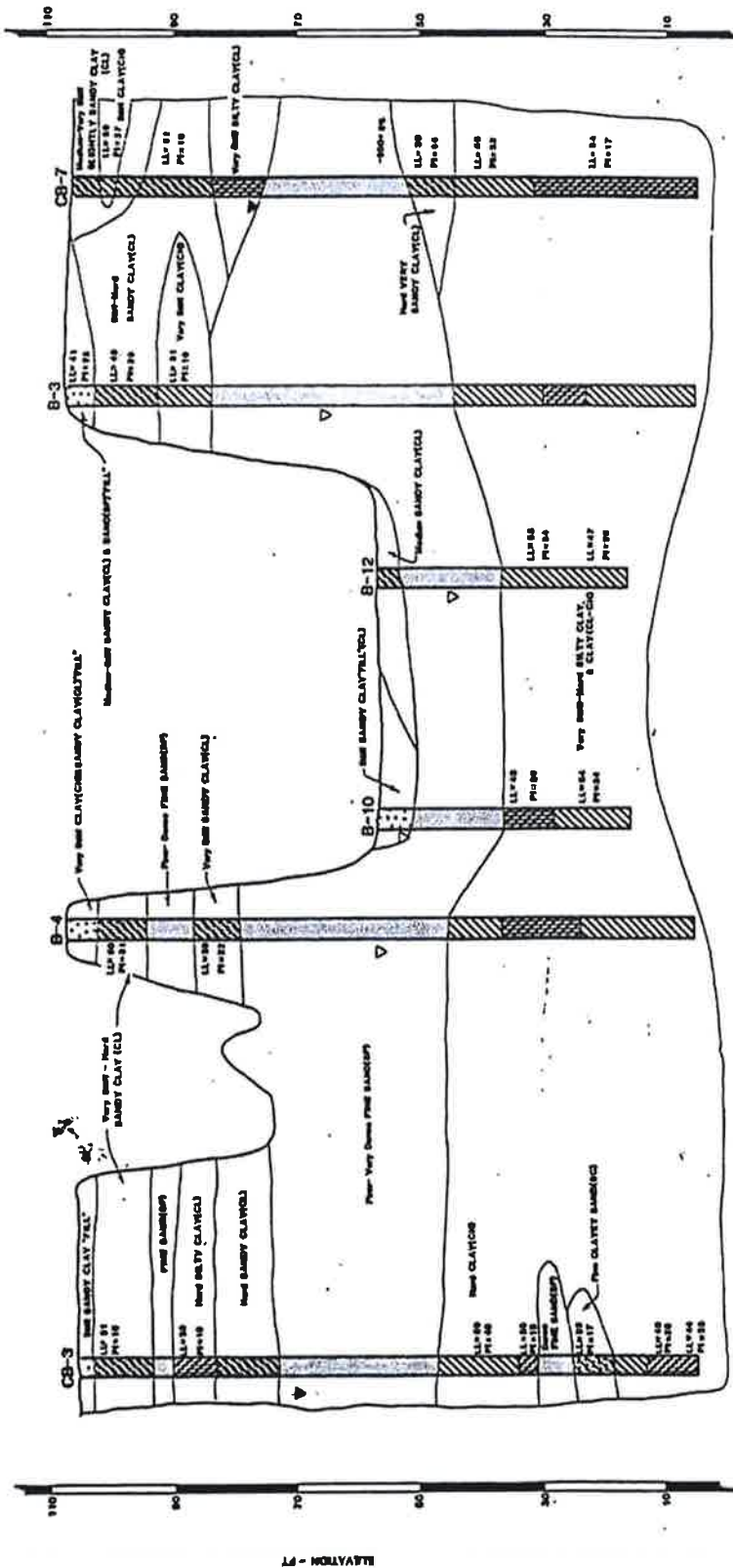

- BORINGS  
 CB-1 DRILLED BY UGA  
 B-1 DRILLED BY AVLES

NOTE - SUBSOIL PROFILE INTERPOLATED BETWEEN BORINGS. ACTUAL CONDITIONS MAY VARY FROM THOSE ILLUSTRATED.

- ▽ OBSERVED STATIC GROUNDWATER LEVEL  
 ▽ FREE WATER ENCOUNTERED

SECTION C-C

**McBride-Ratcliff and Associates, Inc.**  
 Geotechnical Consultants  
 HOUSTON, TEXAS

CRAWFORD STREET TYPE IV LANDFILL  
 HOUSTON, TEXAS

WESTERN CONTRACTORS SERVICES, INC.  
 HOUSTON, TEXAS

DATE NOTED	DATE DRY	DATE 1-28-83	PLATE NO.	93-100
DATE NOTED	DATE DRY	DATE 1-28-83	PLATE NO.	4

SOIL PROFILE



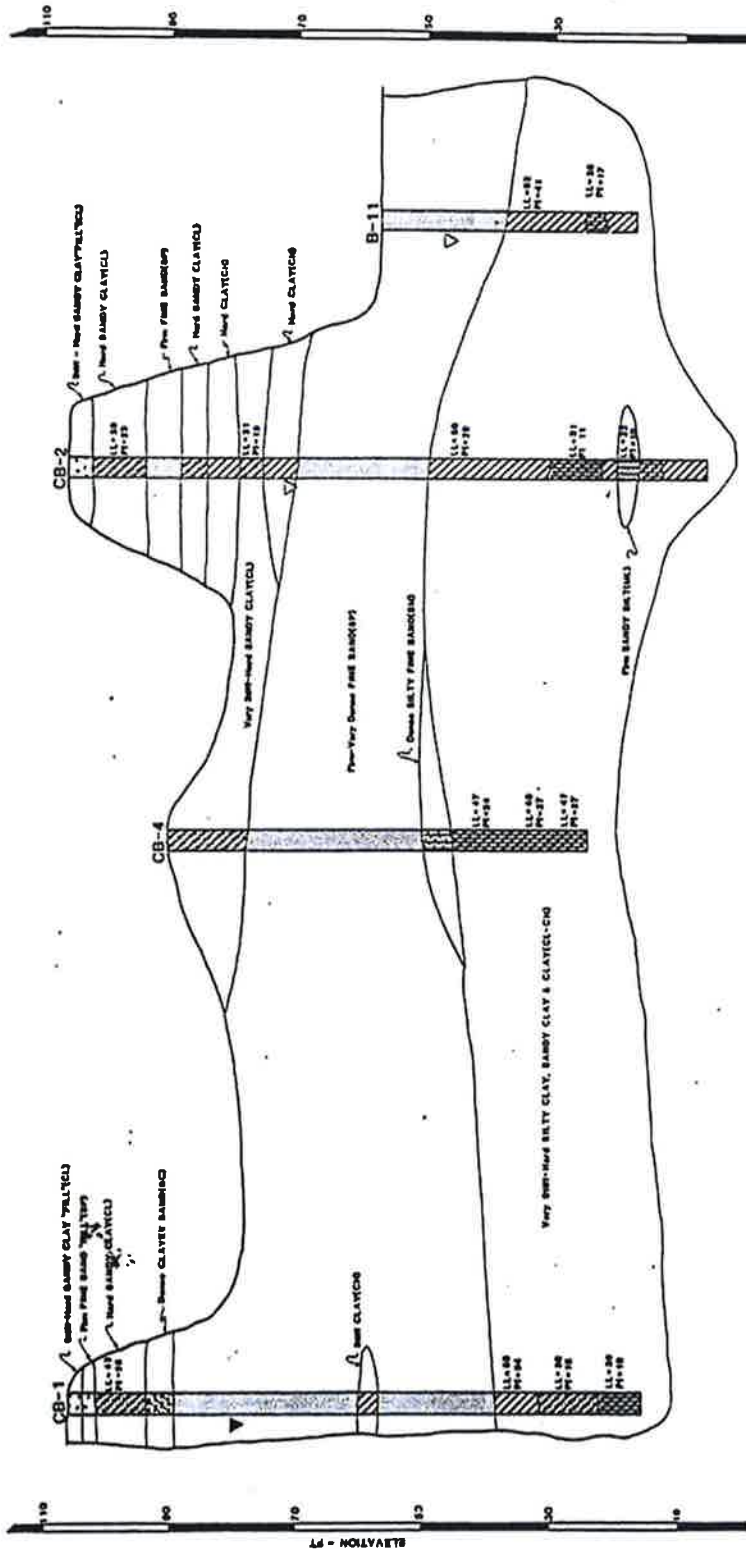

NOTE - BORING PROFILE INTERPOLATED BETWEEN BORINGS. ACTUAL CONDITIONS MAY VARY FROM THOSE ILLUSTRATED.

SCALE - FT  
100

▽ OBSERVED STATIC GROUNDWATER LEVEL  
△ FINE WATER ENCOUNTERED

BORINGS  
CB-1 DRILLED BY MRA  
B-11 DRILLED BY AVEES

SECTION D-D

CRAWFORD STREET TYPE IV LANDFILL  
HARRIS COUNTY, TEXAS

WEBSTER CONTRACTORS SERVICES, INC.  
HOUSTON, TEXAS

McBride-Ratcliff and Associates, Inc.  
Geotechnical Consultants  
HOUSTON, TEXAS

DATE NOTED	DATE	BY
1-24-84	1-24-84	MB
1-24-84	1-24-84	MB

SOIL PROFILE

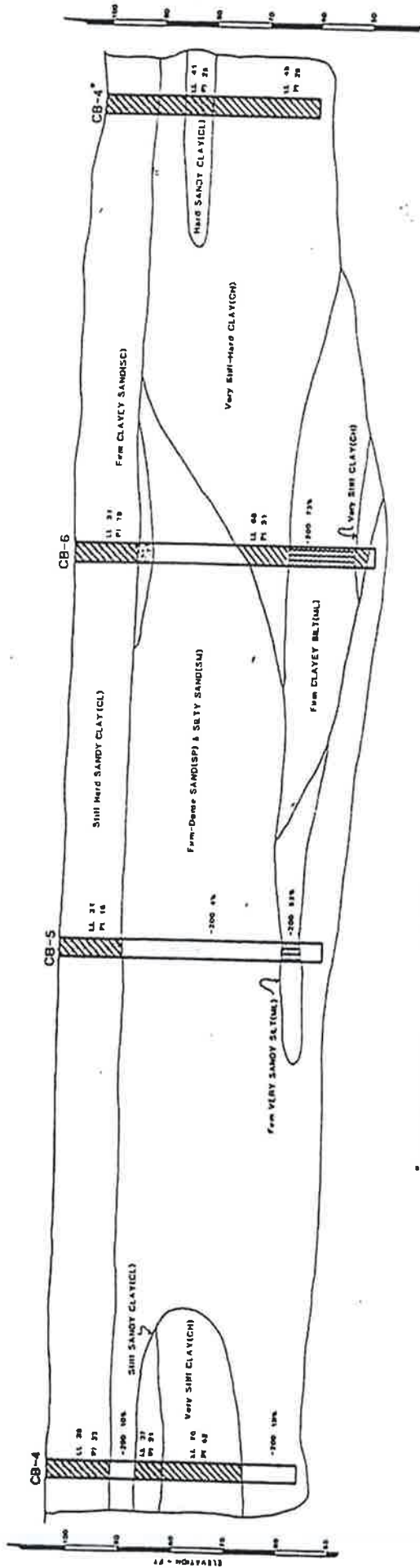
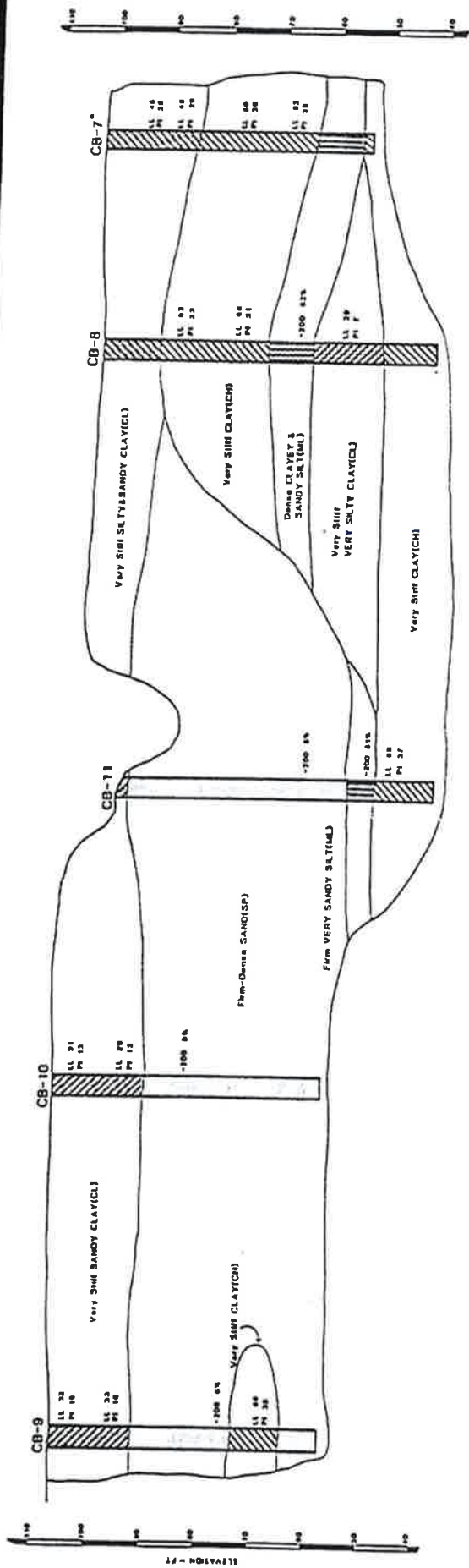

BORINGS DRILLED FOR ORIGINAL SOILS REPORT FOR PERMIT APPLICATION NO. 1448

**TYPE IV LANDFILL**  
 PERMIT APPLICATION NO. 1448-A  
 WASTING COUNTY, TEXAS

**BSI CONSULTING SERVICES, INC.**  
 REGISTRATION NO. 445

**M. Brink-Ratcliff and Associates, Inc.**  
 Geotechnical Consultant  
 11010 W. Loop South, Suite 100  
 Houston, Texas 77042  
 Phone: 281-417-8282  
 Fax: 281-417-8282

**SOIL STRATIGRAPHY -**  
 SECTION 11-4-45

2

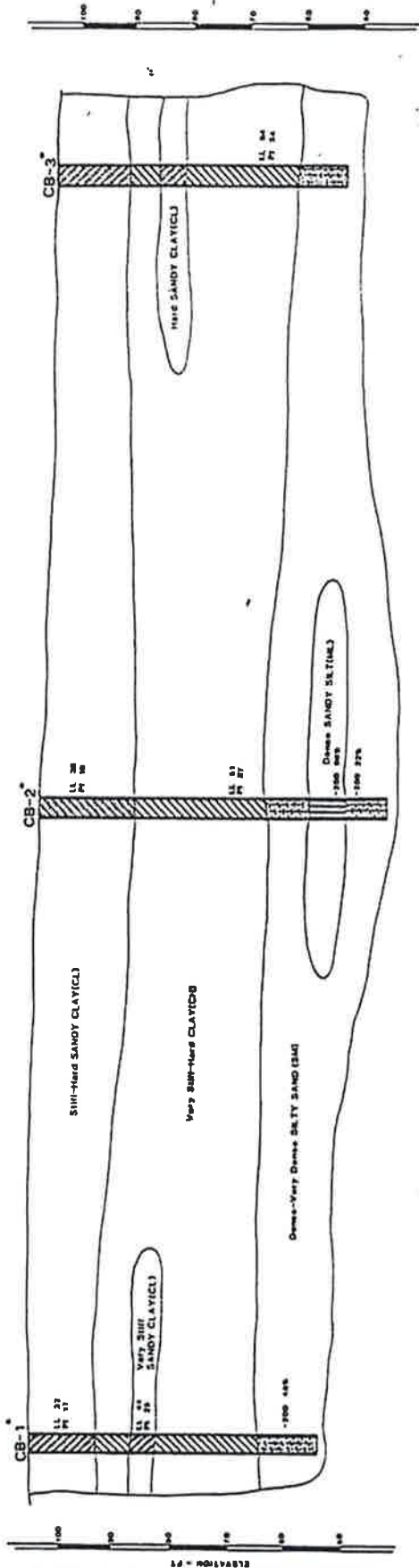
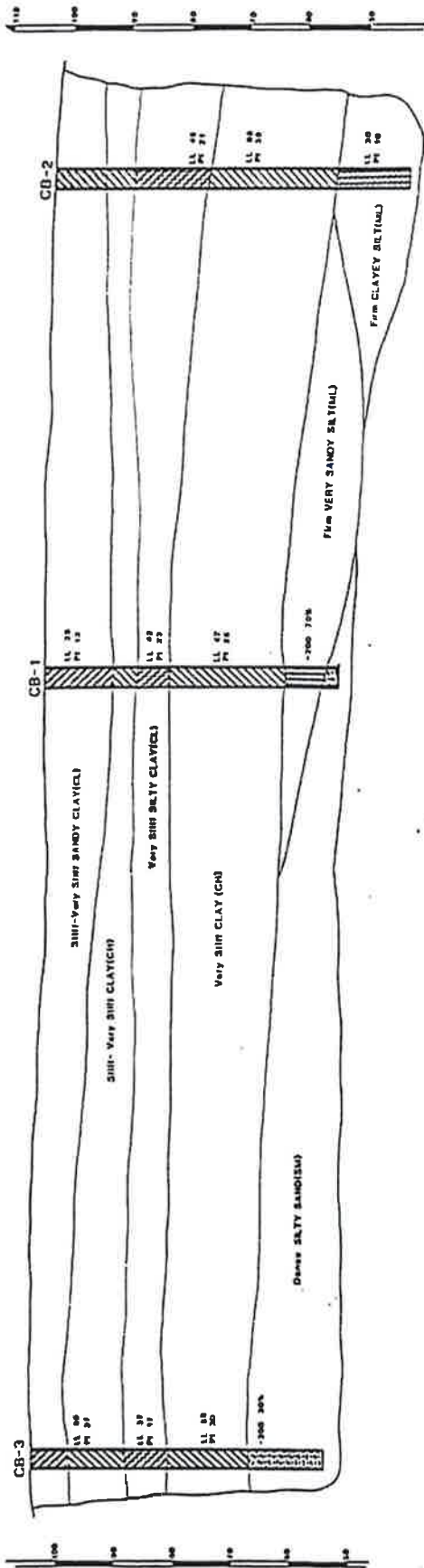

BORINGS DRILLED FOR ORIGINAL SOILS REPORT FOR PERMIT APPLICATION NO. 144B

TYPE IV LANDFILL  
 PERMIT APPLICATION NO. 144B-A  
 HARRIS COUNTY, TEXAS  
 BSI CONSTRUCTION SERVICES, INC.  
 HOUSTON, TEXAS

McBride Ratcliff and Associates, Inc.  
 Geotechnical Engineers  
 14000 Katy Road  
 Houston, Texas 77060  
 SOIL STRATIGRAPHY -  
 NORTHERN EXTENSION  
 DATE: 3-17-82  
 DRAWN BY: J. B. BROWN  
 CHECKED BY: J. B. BROWN  
 SCALE: AS SHOWN  
 SHEET NO. 3



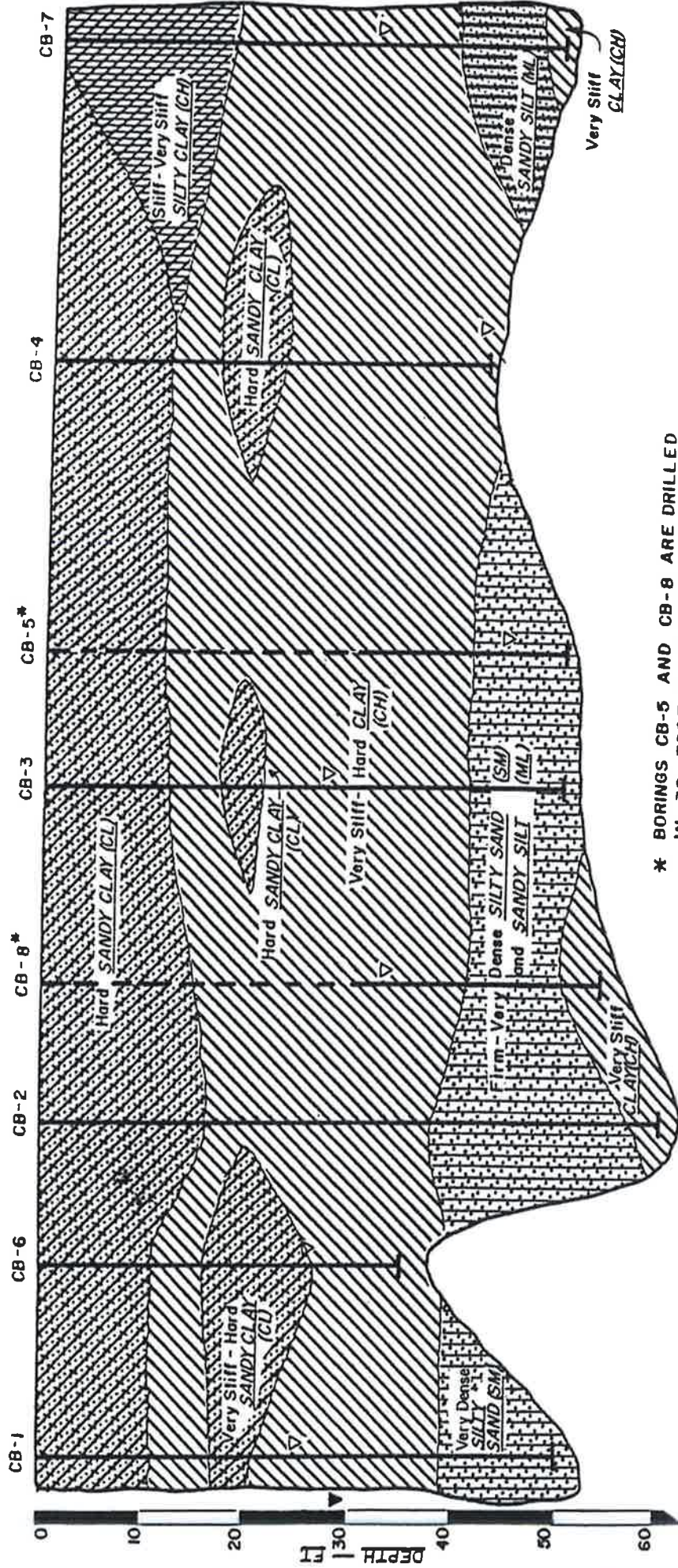

\* BORINGS CB-5 AND CB-8 ARE DRILLED IN 30-FOOT DEEP EXCAVATION.

▼ STATIC GROUNDWATER LEVEL

▽ FREE WATER ENCOUNTERED



III-4H-26

TYPE IV SANITARY LANDFILL APPLICATION  
 HOUSTON, TEXAS  
 B.S.I. CONSTRUCTION SERVICES INC.  
 HOUSTON, TEXAS

McBride-Ratcliff and Associates, Inc.  
 Geotechnical Consulting  
 Houston, Texas

DATE: 5-19-81  
 DRAWN BY: DSF  
 CHECKED BY: PAP  
 PROJECT NO.: 80-269  
 SHEET NO.: 2

SOIL PROFILE

**HISTORICAL GEOTECHNICAL LABORATORY  
TEST RESULTS**



**SUMMARY OF LABORATORY TEST DATA**

**PROJECT** Brush Damelium Landfill, Type 4, Turner St., Morris Co., N.J.  
**DATE** 6-3-77

NOISE NO.	DEPTH IN FEET	TYPE OF MATERIAL	MOISTURE CONTENT %	UNIT WEIGHT			ATTERING LIMITS			COMPRESSION	WATER CONTENT	LATERAL RESISTANCE	OTHER TESTS
				WET	WET	WET	11	10	9				
1	0-10	Stiff light gray and tan sandy clay	13	136	27	17	16					$1.2 \times 10^{-6}$	
	50-60	Very stiff red clay	26	95	53	20	33					$3.6 \times 10^{-6}$	
2	13-15	Dense light gray & tan clayey sand	16	111	27	10	9			( 322 Plover)		$1.9 \times 10^{-6}$	
	50-60	Very stiff red-brown sandy clay with sand pockets	18	104	44	18	26						
3	3-5	Stiff gray & tan sandy clay	14	113	28	17	11					$9.6 \times 10^{-6}$	
	13-15	Light gray and tan silty fine sand, slightly clayey	15	107	22	19	3			( 302 Plover)		$5.3 \times 10^{-7}$	
4	0-10	Very stiff gray and tan sandy clay	16	111	26	17	19					$8.1 \times 10^{-9}$	
	50-60	Very stiff red clay	25	97	50	30	40					$3.2 \times 10^{-9}$	
		Bulk: 902 Standard Proctor	17.7	99.7								$1.0 \times 10^{-6}$	
		Bulk: 952 Standard Proctor	18.0	105								$2.1 \times 10^{-6}$	

MOORE ENGINEERING LABORATORIES



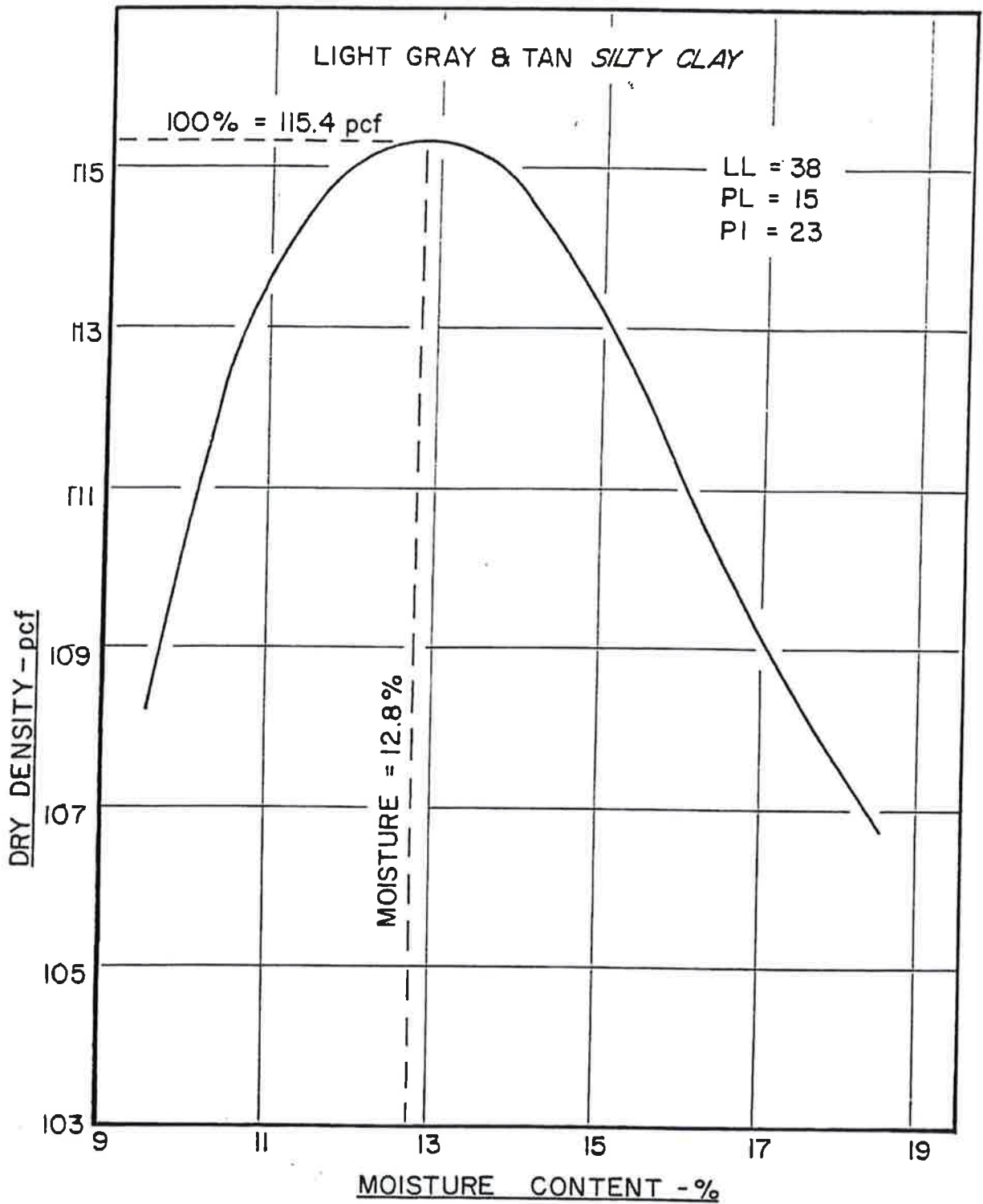

FILE NO. 80-269  
FIG. 4

III-4H-28

# GRAIN-SIZE DISTRIBUTION

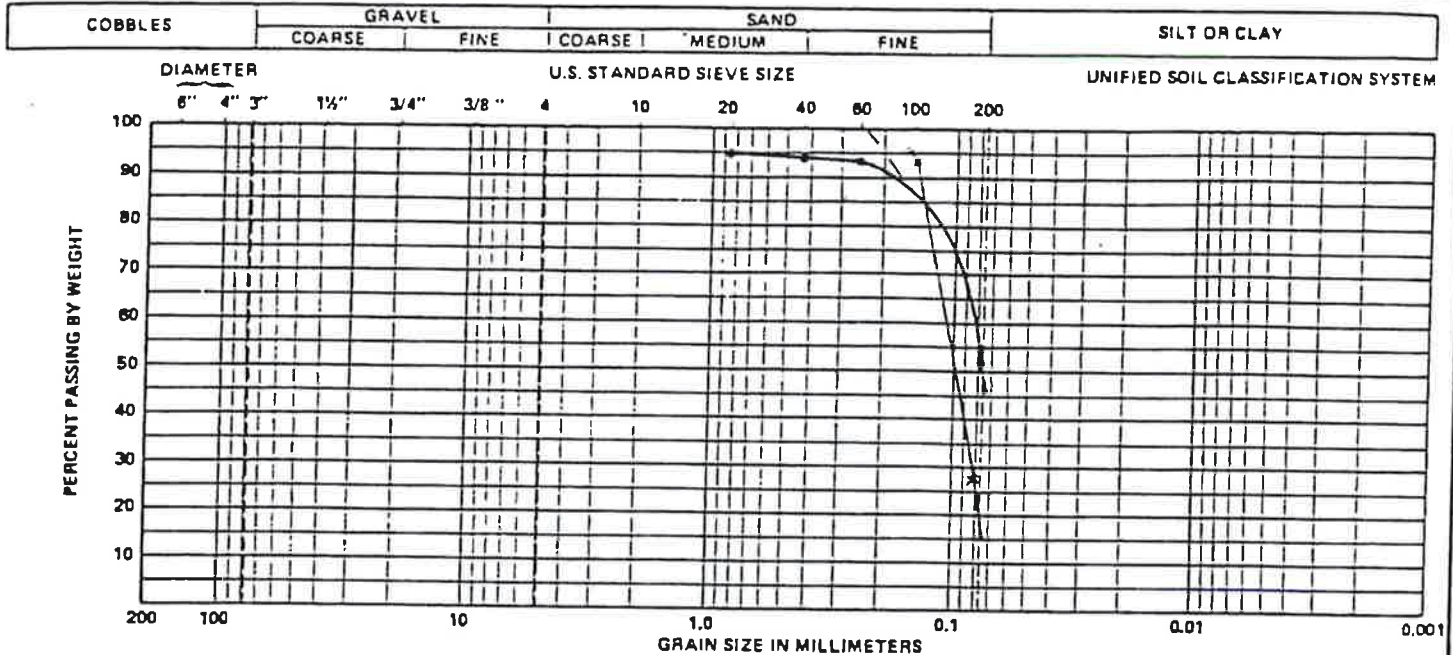

BORING	SAMPLE	DEPTH (ft)	SYMBOL	CLASSIFICATION	w (%)	w <sub>L</sub> (%)	w <sub>p</sub> (%)
CB-1		43.5-45	●	VERY SILTY SAND			
CB-2		53.5-55	✕	SILTY SAND			

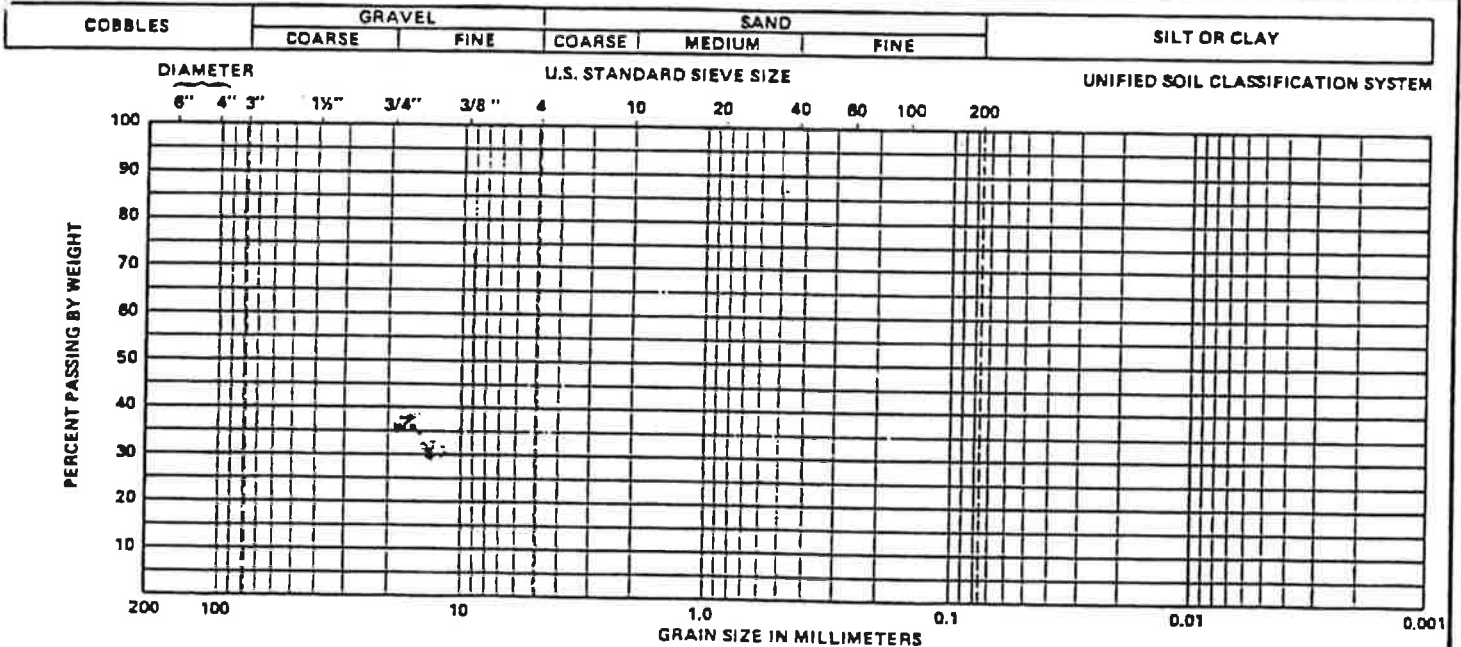

BORING	SAMPLE	DEPTH (ft)	SYMBOL	CLASSIFICATION	w (%)	w <sub>L</sub> (%)	w <sub>p</sub> (%)

COBBLES		GRAVEL		SAND			SILT OR CLAY		
COARSE	FINE	COARSE	FINE	MEDIUM			FINE		

U. S. STANDARD SIEVE SIZES

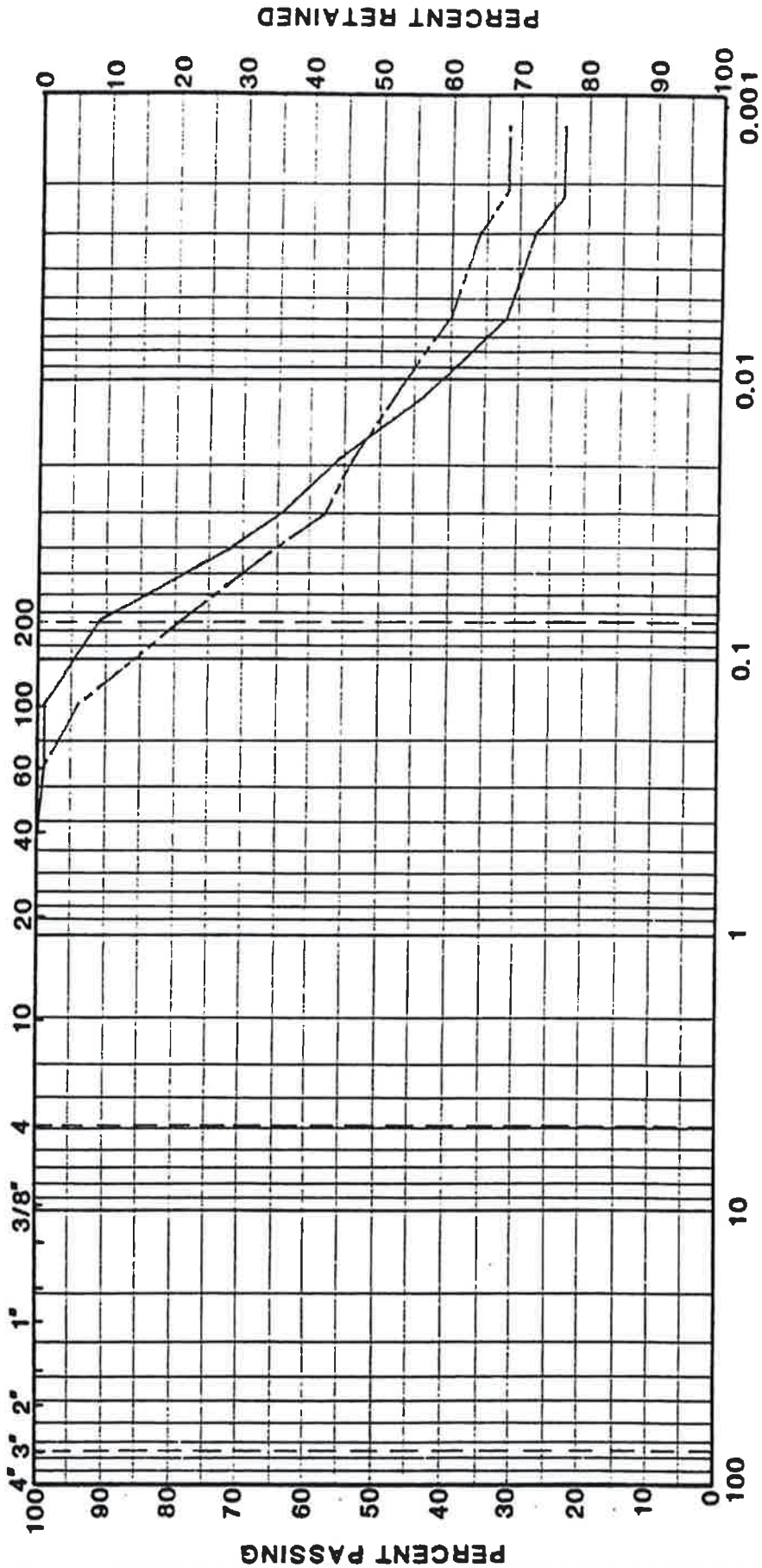

BORING NO.	DEPTH(FT)	CLASSIFICATION	SYMBOL
CB-1	73-75	CL	---
CB-2	2-4	CL	---

GRAIN SIZE DISTRIBUTION  
(UNIFIED SOIL CLASSIFICATION)

FILE NO: 87-028  
FIGURE NO: C-1  
DATE:



COBBLES		GRAVEL		SAND			SILT OR CLAY		
	COARSE	FINE	COARSE	MEDIUM	FINE				

**U. S. STANDARD SIEVE SIZES**

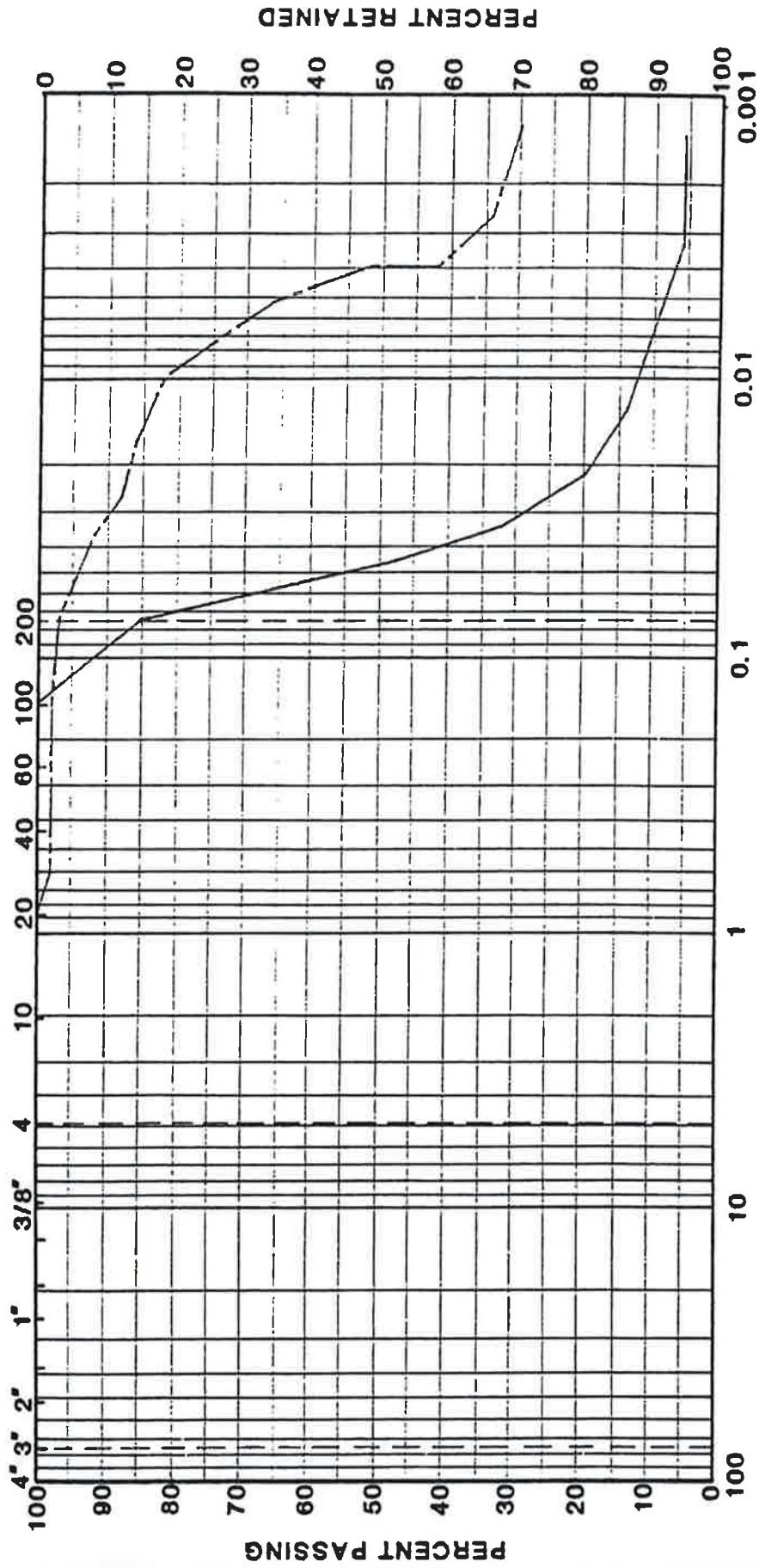

**GRAIN SIZE DISTRIBUTION**  
(UNIFIED SOIL CLASSIFICATION)

BORING NO.	DEPTH(FT)	CLASSIFICATION	SYMBOL
CB-3	63-65	CL	———
CB-4	38-40	CH	- - - -

FILE NO: 87-028  
FIGURE NO: C-2  
DATE:

COBBLES		GRAVEL		SAND			SILT OR CLAY	
COARSE	FINE	COARSE	FINE	COARSE	MEDIUM	FINE		

U. S. STANDARD SIEVE SIZES

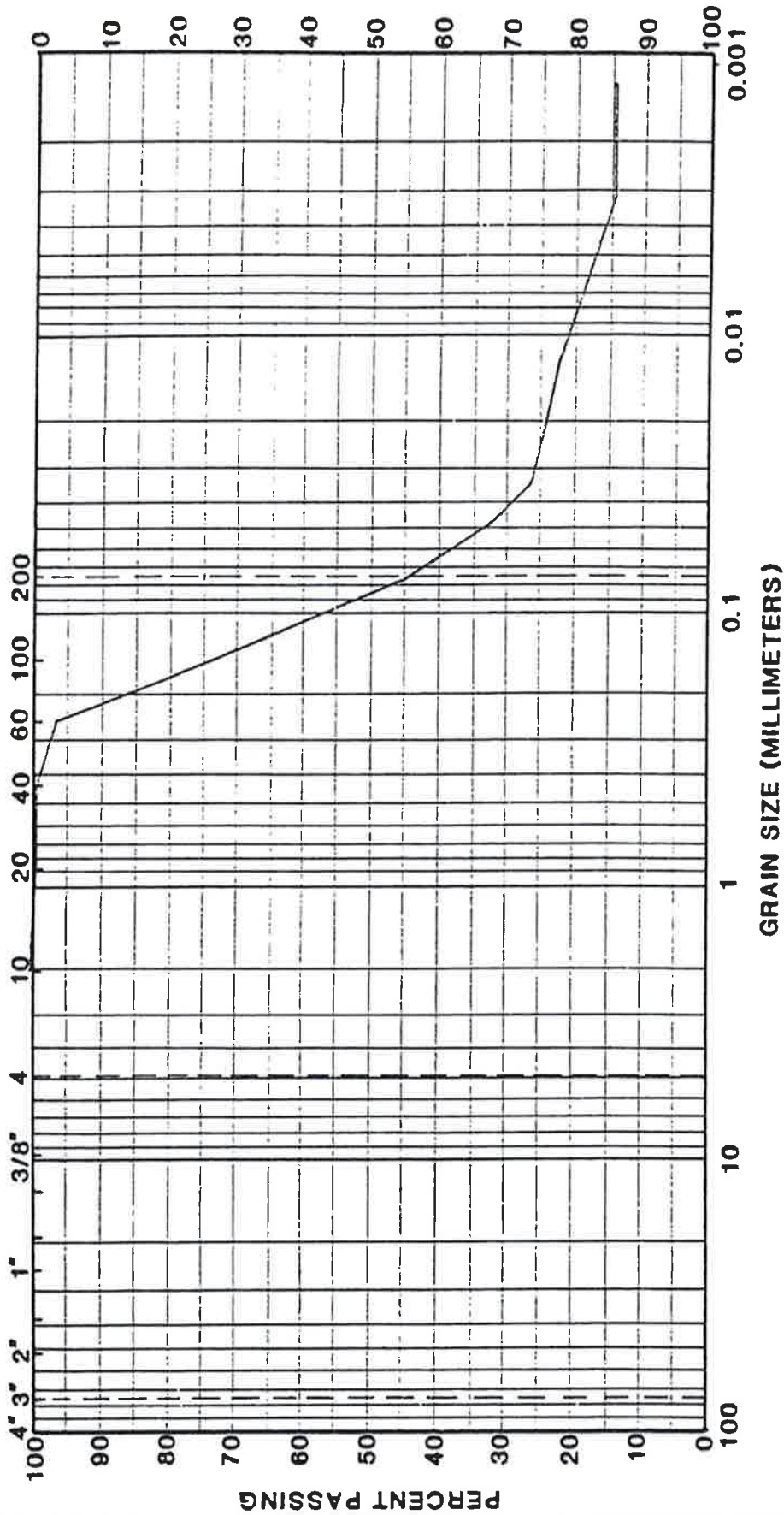

BORING NO.	DEPTH(FT)	CLASSIFICATION	SYMBOL
CB-5	6-8	SC	_____

**GRAIN SIZE DISTRIBUTION**  
(UNIFIED SOIL CLASSIFICATION)

FILE NO: 87-028  
FIGURE NO: C-3  
DATE:

COBBLES		GRAVEL		SAND			SILT OR CLAY		
COARSE		FINE		MEDIUM		FINE			

U. S. STANDARD SIEVE SIZES

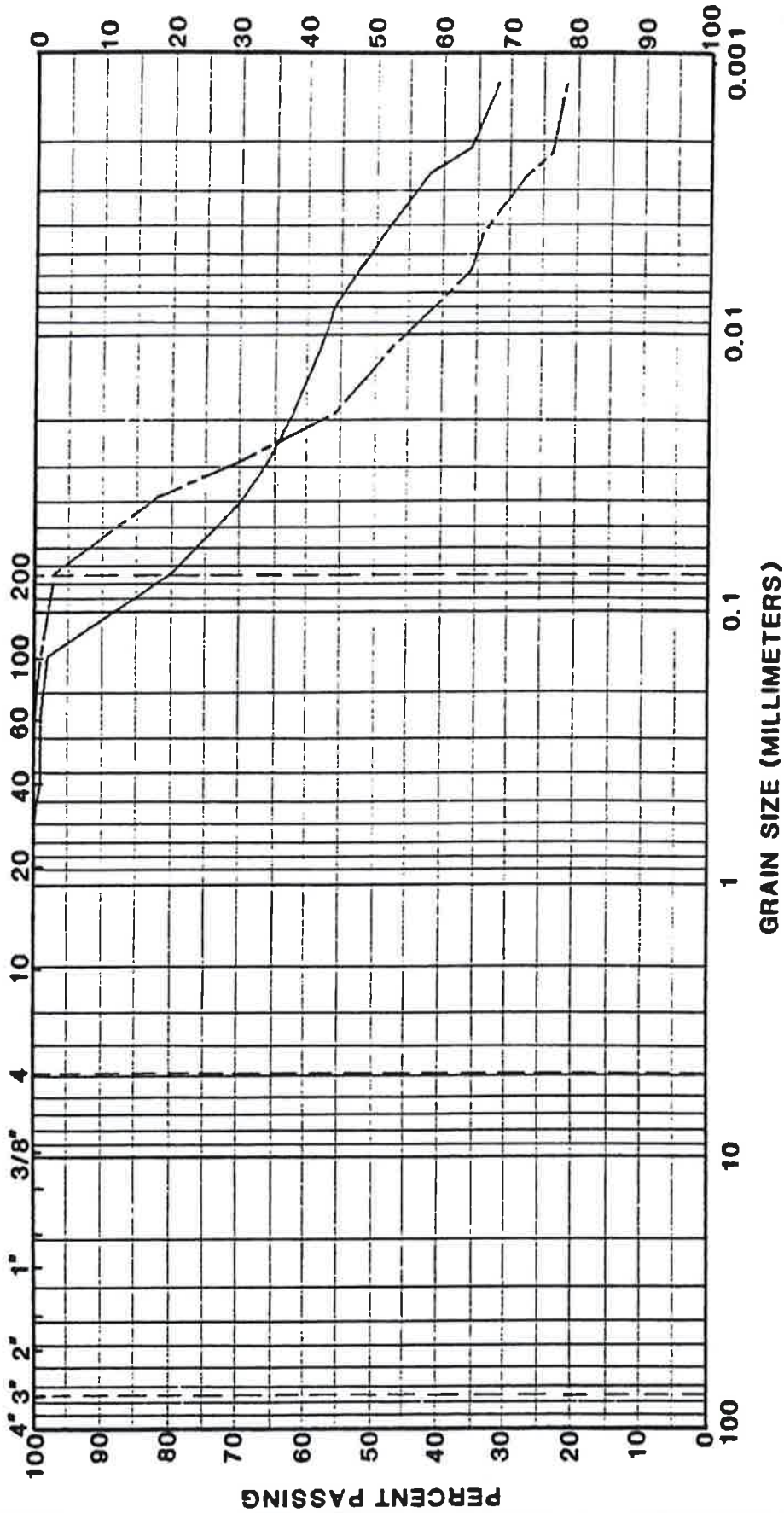

III-4H-33

**GRAIN SIZE DISTRIBUTION**  
(UNIFIED SOIL CLASSIFICATION)

FILE NO: 87-02B  
FIGURE NO: C-4  
DATE:

BORING NO.	DEPTH(FT)	CLASSIFICATION	SYMBOL
CB-6	28-30	CH	—
CB-6	63-65	CH	---



COBBLES      GRAVEL      SAND      SLT OR CLAY  
 COARSE      FINE      COARSE      MEDIUM      FINE

U. S. STANDARD SIEVE SIZES

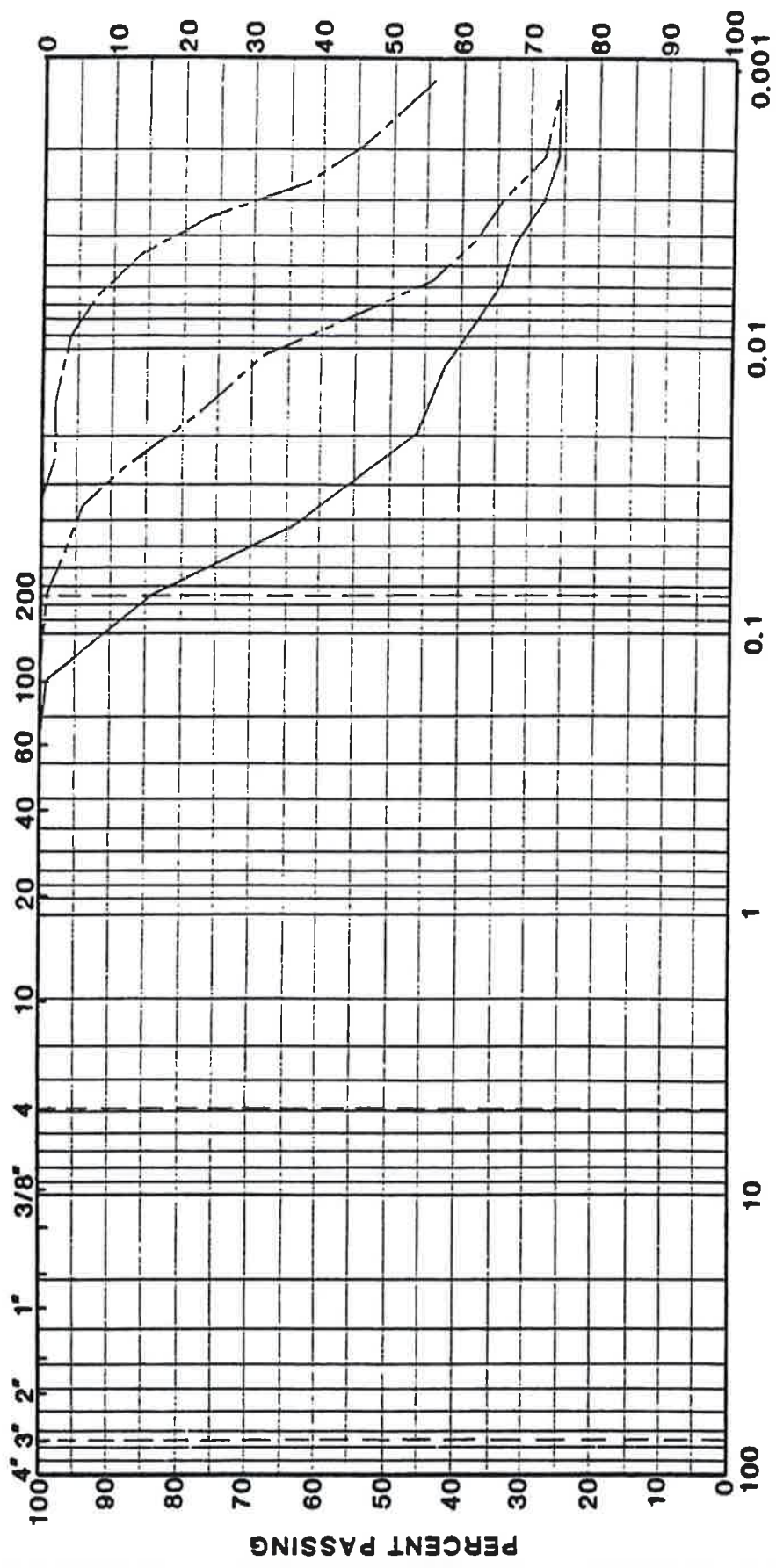

III-4H-34

BORING NO.	DEPTH(FT)	CLASSIFICATION	SYMBOL
CB-8	68-70	CL	—
CB-9	33-35	CH	---
CB-10	63-65	CH	---

GRAIN SIZE DISTRIBUTION  
 (UNIFIED SOIL CLASSIFICATION)

FILE NO: 87-02B  
 FIGURE NO: C-6  
 DATE:

COBBLES      GRAVEL      SAND      SILT OR CLAY  
 COARSE      FINE      COARSE      MEDIUM      FINE

U. S. STANDARD SIEVE SIZES

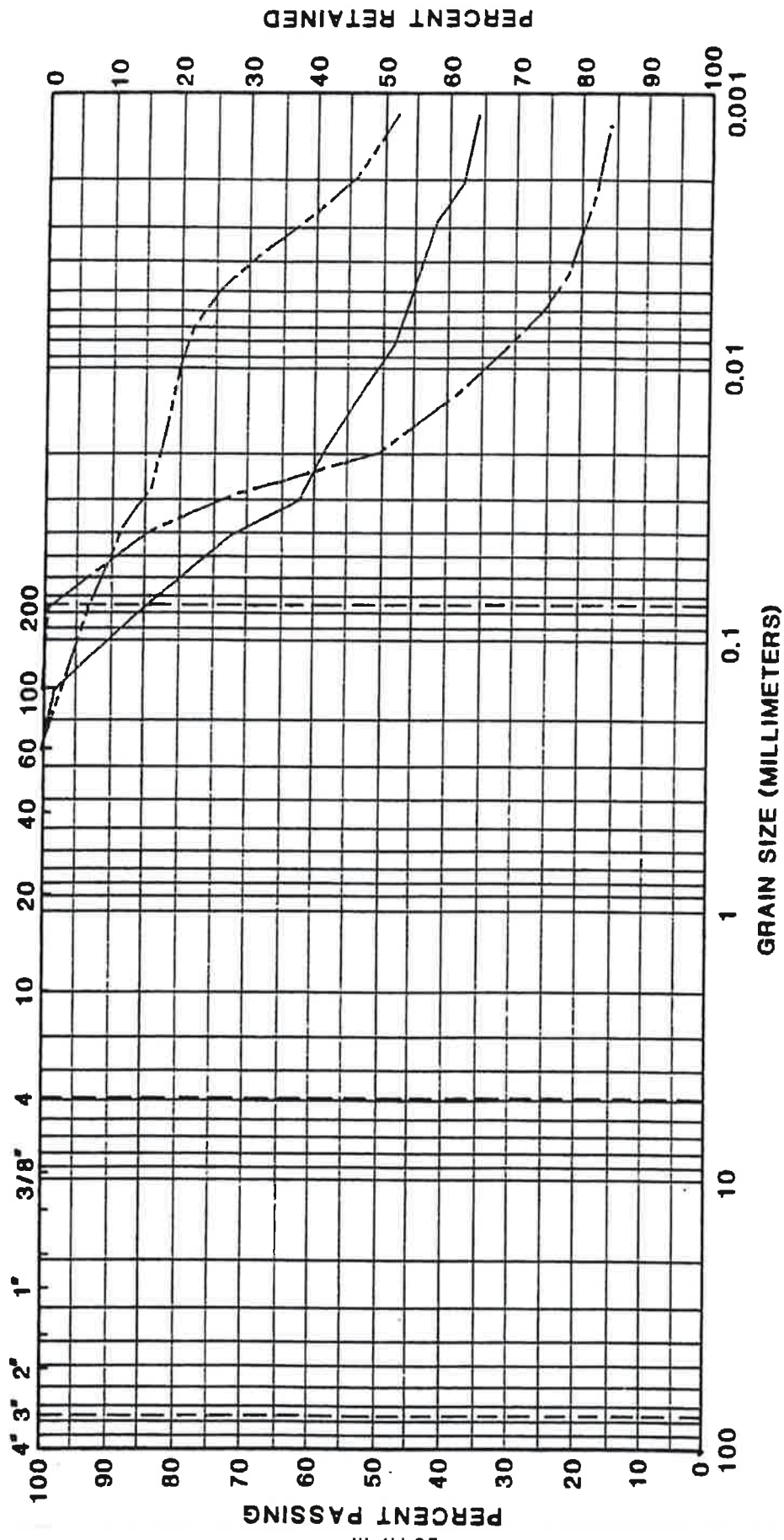

III-4H-35

BORING NO.	DEPTH (FT)	CLASSIFICATION	SYMBOL
CB-11	68-70	CL	—
CB-11	78-80	ML	---
CB-13	23-25	CH	---

GRAIN SIZE DISTRIBUTION  
 (UNIFIED SOIL CLASSIFICATION)

FILE NO. : 87-028  
 FIGURE NO. : C-6  
 DATE :

COBBLES		GRAVEL		SAND			SILT OR CLAY		
COARSE	FINE	COARSE	FINE	MEDIUM	FINE				

U. S. STANDARD SIEVE SIZES

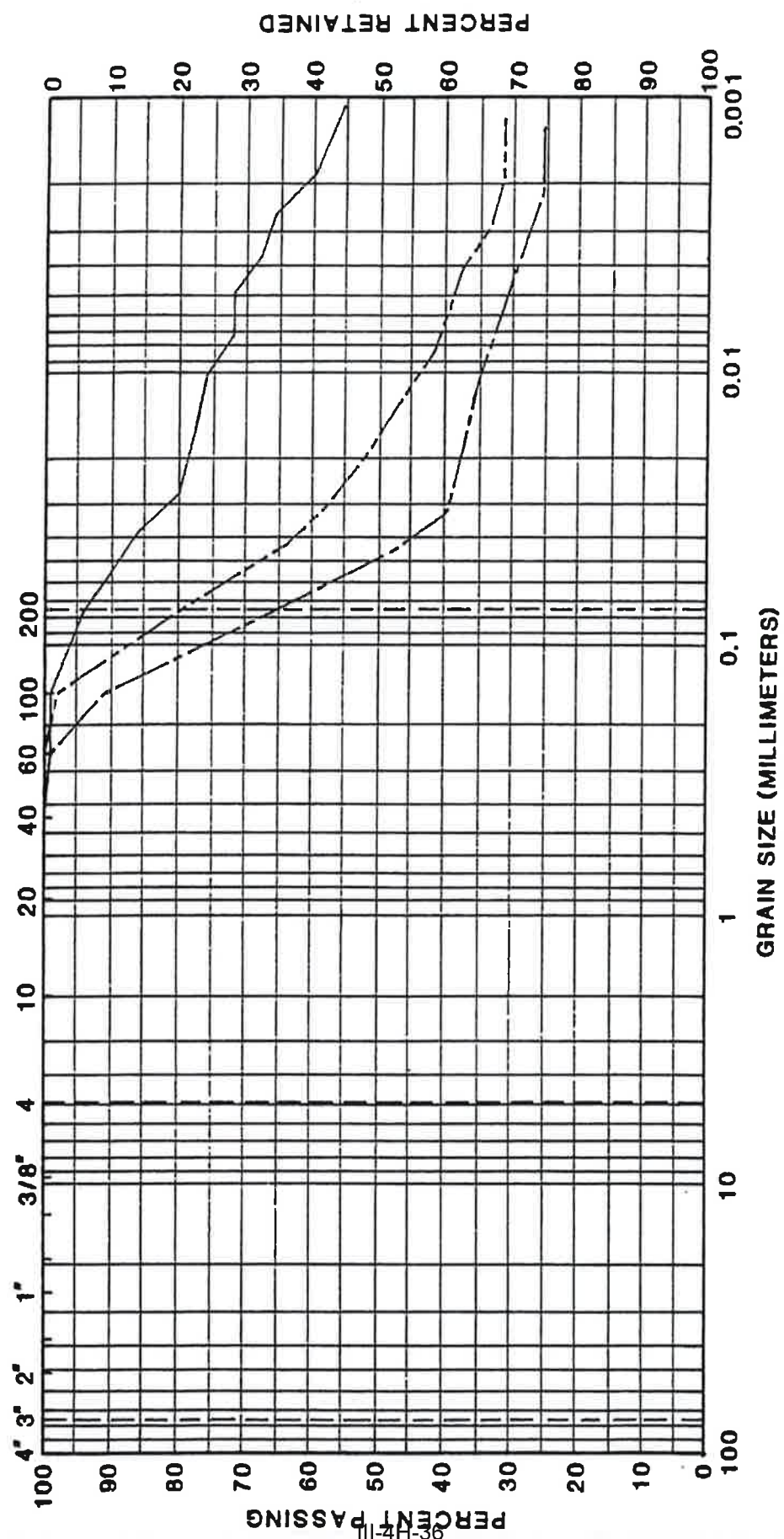

BORING NO.	DEPTH (FT)	CLASSIFICATION	SYMBOL
CB-14	68-70	CH	—
CB-15	8-10	CL	---
CB-16	18-20	ML	- - -

GRAIN SIZE DISTRIBUTION (UNIFIED SOIL CLASSIFICATION)

FILE NO.: 87-028  
 FIGURE NO. G-7  
 DATE:



COBBLES		GRAVEL		SAND			SILT OR CLAY	
COARSE	FINE	COARSE	FINE	MEDIUM	FINE			

U. S. STANDARD SIEVE SIZES

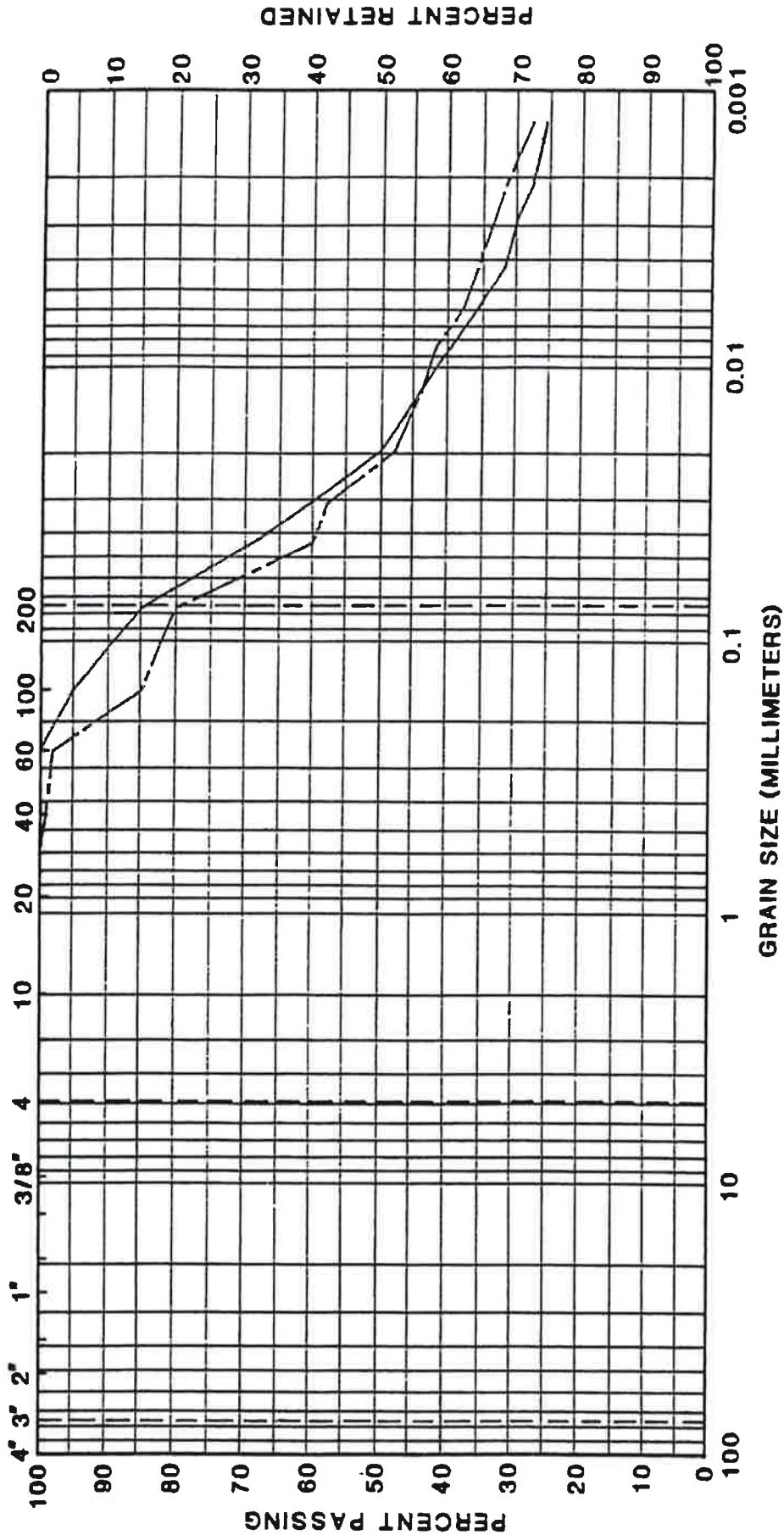

GRAIN SIZE DISTRIBUTION (UNIFIED SOIL CLASSIFICATION)

FILE NO. : 87-028  
 FIGURE NO. C-9  
 DATE :

COBBLES		GRAVEL		SAND			SILT OR CLAY					
4"	3"	2"	1"	3/8"	4	10	20	40	60	100	200	FINE
			COARSE	FINE	COARSE	MEDIUM						

U. S. STANDARD SIEVE SIZES

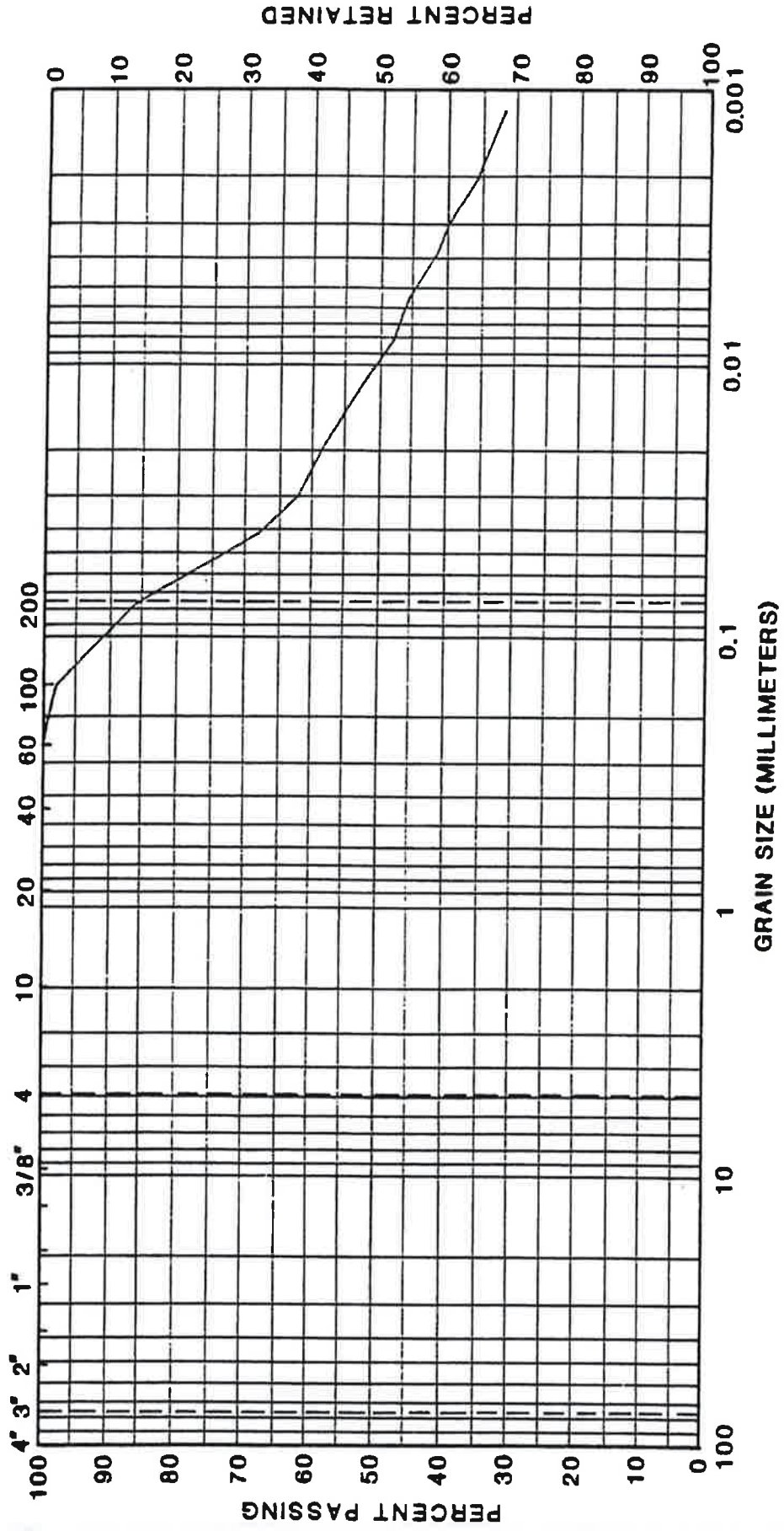

BORING NO.	DEPTH (FT)	CLASSIFICATION	SYMBOL
CB-16	73-75	CL	—

**GRAIN SIZE DISTRIBUTION**  
(UNIFIED SOIL CLASSIFICATION)

FILE NO.: 87-028  
 FIGURE NO. C-8  
 DATE :

III-4H-38

COBBLES		GRAVEL		SAND			SILT OR CLAY	
4"	3"	2"	1"	3/8"	4	10	20	40
					COARSE	MEDIUM	FINE	

U. S. STANDARD SIEVE SIZES

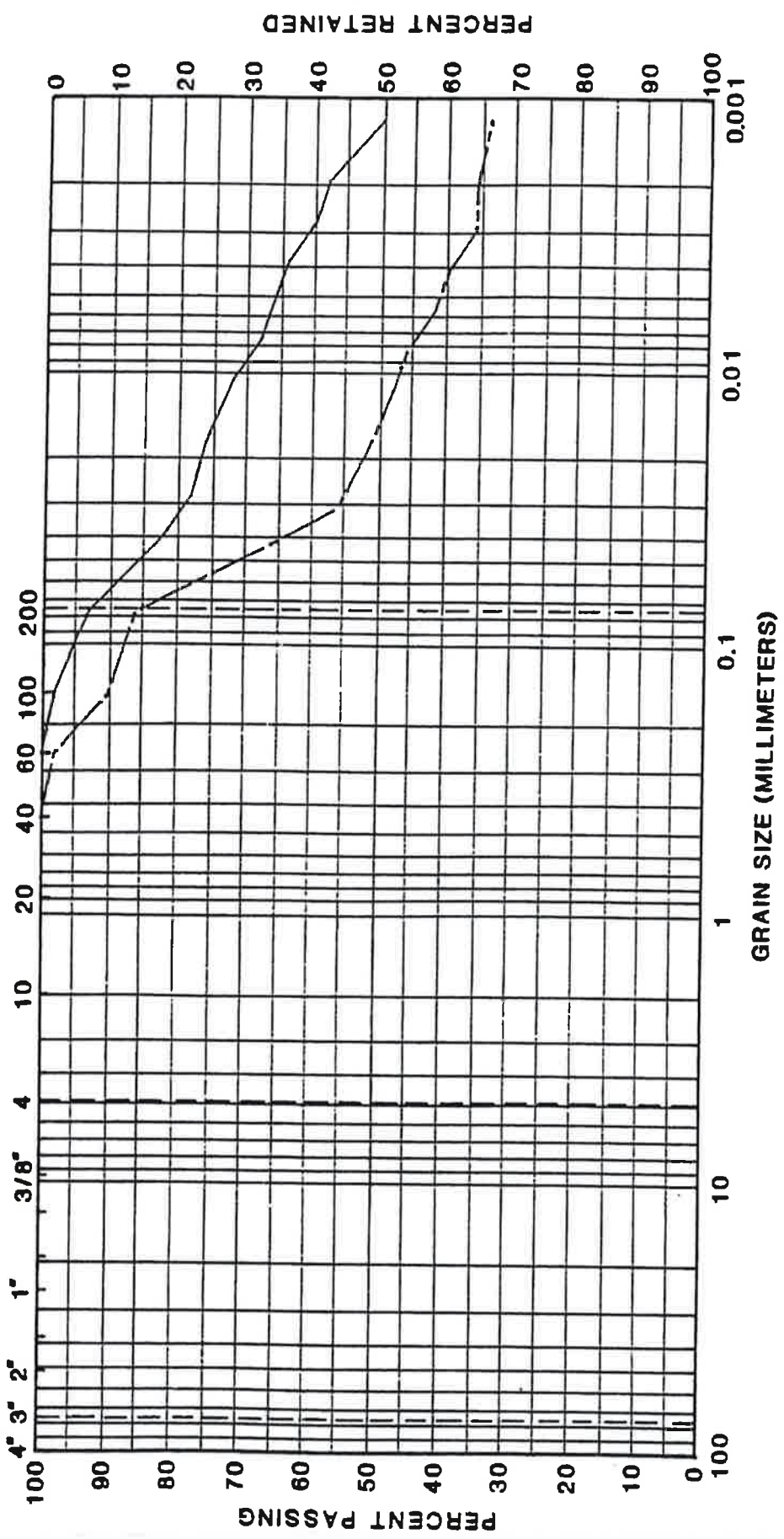

III-4H-39

BORING NO.	DEPTH(FT)	CLASSIFICATION	SYMBOL
P-4P	58-70	CL	—
P-5PA	72-74	CL	---

GRAIN SIZE DISTRIBUTION (UNIFIED SOIL CLASSIFICATION)

FILE NO. : 87-028  
 FIGURE NO. C-10  
 DATE :